

HYDRAULICS CATALOGUE

Hose & Fittings

(January, 2004)



NATIONAL HOSE AND EQUIPMENT LTD.

TEL: 416-298-0494 • Fax: 416-298-0626 • EMAIL: nathose@aol.com • www.national-hose.com

CONDITIONS OF SALE

1. All our agreements contingent upon accidents, strike, fires and unavoidable delays, and causes beyond our control.
2. Every effort is made by us to offer equipment and/or material to suit conditions stated by the purchaser but he shall be taken to have satisfied himself that any goods ordered will meet his requirements. We can accept no liability if it should prove otherwise, providing goods supplied comply with the quotation or tender.
3. Everything in our power is done to ensure good material and workmanship but owing to the nature of our products and the greatly varying working conditions, it is not feasible to guarantee a working life.
4. No term proposed by the buyer which is inconsistent with any of the terms set out in this document shall, whether expressly excluded or not have any effect upon the agreement.
5. Under no circumstances, herein contained or not, shall our company be under any liability for consequential or other damages.

CLAIMS ON DAMAGED PRODUCTS

Since our liability ceases when goods are delivered to the transportation company, **all claims on damaged goods received, with apparent or concealed damages, must be made to the transportation company concerned** Should there be any special shipping information required with respect to said shipment, we will be happy to advise.

SALES TAX STATUS

All our prices exclude federal and provincial sales tax. However when applicable, both taxes will be charged to the purchaser unless we have received the necessary certifications or exemptions.

SHIPPING TERMS

F.O.B. our plant unless otherwise agreed to in writing by ourselves.

TERMS OF PAYMENT

Net 30 Days unless otherwise agreed to in writing by ourselves. Payment Methods Accepted: Visa, Mastercard, Debit, Cash, Cheque and Bank with Transfer

NOTE

Before accepting any order we reserve the right to change or cancel any prices and/or condition of sale without previous notice, except when agreed to in writing by ourselves.

WARRANTY

Merchandise is warranted to be free from defect in material or workmanship. Liability under any express or implied warranty is limited to the purchase price of any merchandise proven defective, or at seller's option, to replacement of such merchandise. This warranty is in lieu of all other warranties expressed or implied and all other obligations or liabilities on the part of National Hose.

RETURNS POLICY- R.G.A. Number is a MUST for all returned goods

Cancellation of orders or return of goods cannot be accepted by us without a R.G.A. number or written consent given previously and on terms agreed to in writing by us. Authorized returns are subject to a minimum 20% re-stocking charge and freight must be prepaid, some products are non-returnable.

SALES DISCOUNTS

NATIONAL HOSE

The National Hose Concept

NATIONAL HOSE & EQUIPMENT LTD - is proud to offer our all new complete line of fluid power products into the world market place. This complete product line of hose, couplings & crimpers is part of our new **T.A.P** (Tested Assembly Program) that will ensure **Quality** and continued **Safety** of our products in any market place.

The product line in this catalogue is made up of hose products, coupling styles, crimping equipment and protection products. In addition we also offer a complete line of hydraulic adapters made to SAE specifications in steel, brass and 304/316 stainless steel. Our large range and special MTO custom styles make our hydraulic adapter product line a perfect match for our hydraulic hose & coupling products. We also offer complete lines of hydraulic quick disconnects, tube clamps, filters, flange & flange adapters, Imperial & Metric compression tube fittings, metric & bsp conversion adapters, gauges dry & liquid filled, & high pressure ball valves & O-ring kits.

National Hose & Equipment has been, and will continue to offer the Distributor, OEM, or End user a complete line of products both Industrial & Hydraulic that will meet or exceed the industry standards. This is because as important as standards are, **National Hose** is committed to an even higher and more important standard, yours the customer. You are the driving force why National Hose is committed to constantly listening to and acting on any concerns, needs, and NEW IDEAS.

National Hose & Equipment product lines are made available to all major markets & geographic areas around the world. However we will always forward any new or potential customers to our established, **DISTRIBUTORS FIRST** in a selected area or agreed geographic listing. This is a part of our **commitment** to you, to keep the open lines of communication with our loyal partners so we can continue to grow business for all party's involved. Please **contact National Hose for your local Distributor or stocking location.**

This catalogue gives you most of the popular products stocked by National Hose & Equipment for hydraulic hose, couplings, crimpers, & protection products. There are some hose styles, coupling sizes as well as crimper styles, and protection products, that we do not keep as a standard stock item this is to keep more shelf space for higher volume and quicker moving items required by our customers. **Please feel free to call and check our stock and or delivery time.**

NATIONAL HOSE

TABLE OF CONTENTS GENERAL INFORMATION

	PAGE
Quality -----	4
Hydraulic Hose and Coupling Compatibility -----	5
Selecting Hose I.D. By Flow and Velocity -----	6
Sae Specifications -----	7
Hose Installation Tips -----	8
S.T.A.M.P.E.D Hose & Assembly Request Form -----	9
Thread Standards -----	10-18
End Style Chart New National Hose to Old Dayco Eastman -----	19-20
How to Read Part Number System -----	21
Hose Selection By Size & Pressure -----	22
Fraction Conversion Chart -----	84
Conversion Factor Chart -----	85
Pressure Conversion Chart -----	86
Thread Size Match Up Chart -----	87
Hex & Flange Size Match Up Chart -----	88
Part Number Index -----	89-90

Rubber Hose Products With Braided Reinforcement

Series MXI -----SAE 100R1AT / EN 853 1SN-----	23
Series BXI -----SAE 100R2AT / EN 853 2SN-----	23
Series AMI-----SAE 100R17-----	24
Series FXI-----SAE 100R16-----	24
Series PFI-----POWERFLX-----	25
Series JL-----SUPERJACK-----	25
Series PW-----PRESSURE WASH-----	26
Series PW-NM / 4657-----PRESSUR WASH NON-MARKING-----	26
Series PWHP-----PRESSURE WASH HIGH PRESSURE-----	26
Series R4-----SAE 100R4 RETURN LINE-----	27
Series AU-05-----FLEX-LOC PUSH ON-----	27
Series R5-----SAE 100R5 COTTON COVER-----	28

Rubber Hose Products With Spiral Reinforcement

Series CEI -----SAE 100R12 / EN 856 R12-----	35
Series 4SP/4SH-----EN 856 4SP / EN 856 4SH-----	35
Series NHI-----SAE 100R13 / EN 856 R13-----	36
Series N2I -----SAE 100R15 / EN 856 R15-----	36

-SEE NEXT PAGE FOR MORE INFO-

NATIONAL HOSE

TABLE OF CONTENTS GENERAL INFORMATION

	PAGE
Thermoplastic Hose Products With Braided Reinforcement	
Series R7-----SAE 100R7-----	29
Series R7-NC-----SAE 100R7 NON CONDUCTIVE-----	29
Series R7TL-----SAE 100R7 TWIN LINE-----	30
Series R7TL-NC-----SAE 100R7 TWIN LINE NON CONDUCTIVE-----	30
Series R8-----SAE 100R8-----	31
Series R8-NC-----SAE 100R8 NON CONDUCTIVE-----	31
Specialty Hose Products	
Series BH-----SAE J51 & J2064 BARRIER REFRIG-----	28
Series T1-----SAE 100R14A SMOOTHFLEX TEFLON-----	32
Series PFSS-----PROFLEX CONVOLUTED TEFLON-----	32
Series HPS-----HIGH PRESSURE PAINT SPRAY-----	33
Series XHPS-----HIGH PRESSURE PAINT SPRAY ASSEMBLIES-----	33
Series WB-----HIGH PRESSURE WATERBLAST-----	34
Series XWB-----HIGH PRESSURE WATERBLAST ASSEMBLIES-----	34
Permanent Crimp Couplings	
Series NH-----	37-49
Series TC-----	50-57
Series BW-----	58-65
Series JJ-----	66-69
Specialty Couplings	
Series BL-----	70-71
Series ST / BR-----	72-73
Series PF-----	74
Series D360-----	75
Crimpers & Tooling	
Series D100SDC & D105DC-----	76
Series D205DC-----	77
Series D206DC-----	Coming Soon
Series D305DC-----	Coming Soon
Series FLEX CRIMP 2000-60DC-----	Coming Soon
Series FLEX CRIMP 2000-100DC-----	Coming Soon
Protection Products & Accessories	
Series PG - POLYGUARDS-----	79
Series NHS - NYLON HOSE SLEEVE-----	79
Series TFG - TECTORFLEX LIGHT DUTY HOSE WRAP-----	80
Series SGX - TECTORGUARD MEDIUM & HEAVY DUTY HOSE WRAP-----	80
Series SFS - SILICONE FIRE SLEEVE-----	81
UC-EL-7DP ULTRACLEAN HOSE TUBE & PIPE CLEAN OUT SYSTEM-----	82
ENVIRO SAFE PRODUCTS-----	83
HYDRAULIC OIL & OIL ABSORBENT-----	83

NATIONAL HOSE

QUALITY

Our Manufacture utilizes a variety of planning and process monitoring tools to provide quality products: FMEA'S, advanced quality planning meetings, process flow diagrams, X Bar & R charting, histograms, and capability studies.

Ongoing audits ensure compliance to the company's quality policy, quality manual, quality assurance procedures, and ISO/QS certified quality management systems.

Our Manufacture maintains a gage inventory of several thousand gages, ranging from cylindrical plug gages, thread gages, and micrometers to optical comparators and computer gage systems.

Gages used for product acceptance are tracked for calibration frequency and compliance through a computerized gage control system that provides for a positive recall of any gage requiring calibration. Calibrations are traceable to NIST Standards.



NATIONAL HOSE

HYDRAULIC HOSE AND COUPLING COMPATIBILITY

There are a number of SAE Standards that cover the performance requirements of hydraulic hose assemblies. Included are the J517, J516, and J343 Standards.

Hydraulic hoses that are claimed to meet SAE J517 standards (e.g. SAE 100R1 and SAE 100R2) obviously need to be designed for, and certified to, the criteria defined by SAE. That criteria include stringent dimensional tolerances (inside, outside, and braid diameters), compound and reinforcement types, length changes, cold flexibility, and ozone and heat resistance. There are also burst pressure and impulse requirements in J517. Those requirements are for coupled assemblies, and SAE states that “the general and dimensional standards for hydraulic hose fittings are obtained in SAE J526.”

Hydraulic hose fittings that meet SAE J516 Standards are similarly well defined by SAE as to material type, dimensions, finish, etc. The SAE manual also specifically states that J516 fittings are intended to be used “in conjunction with hydraulic hoses specified in SAE J517, and utilized in hydraulic systems on mobile and stationary equipment.”

SAE J343 is the standard that establishes “uniform methods of the testing and performance evaluation of the SAE 100R series of hydraulic hose and hose assemblies.” Coupled assemblies are expected to meet or exceed SAE performance if the SAE criteria described above are met.

The integrity of any hose assembly depends upon the components, fittings, and hose meeting the rigorous SAE requirements, and then the components being assembled by skilled personnel. This is true regardless of where the components are manufactured. Testing has been completed on ***National Hoses brand of fittings coupled to Markwel hydraulic hoses***, and the tested assemblies have passed SAE performance criteria.

While there has been an integration of hose and fitting manufacturers, independent hose and fitting manufacturers can and will continue to produce top class products that will provide excellent assemblies just as they have done for decades.

NATIONAL HOSE

SELECTING HOSE I.D. - FLOW and VELOCITY

Selecting Hose I.D. - Flow and Velocity

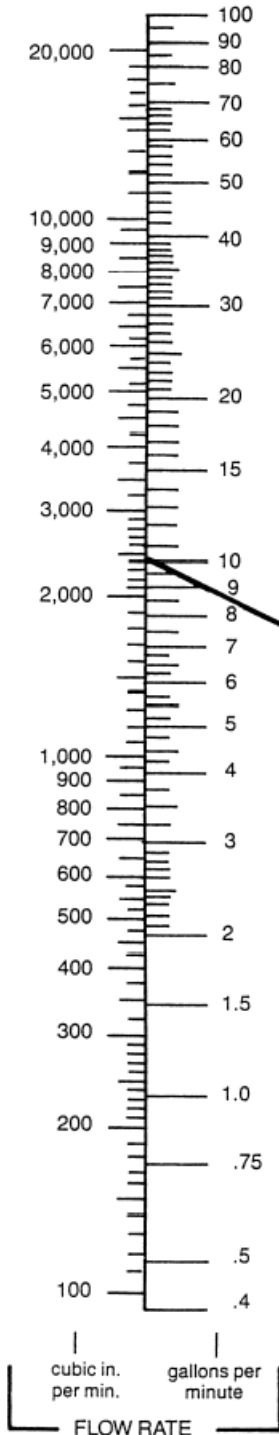

This chart is used to determine the size of hose needed to fill flow rate and velocity requirements.

Place a straightedge along a line from the flow rate column to the velocity column. The recommended hose size is shown at the point where the line crosses the Hose I.D. column. If the line crosses the Hose I.D. column between sizes, use the next larger I.D.

In the illustration, a 5/8" hose is recommended for a 10 gpm flow rate at a 10 fps velocity.

NOTE: Unless flow of hydraulic fluid is intermittent or occasional, recommended velocities should not be exceeded.

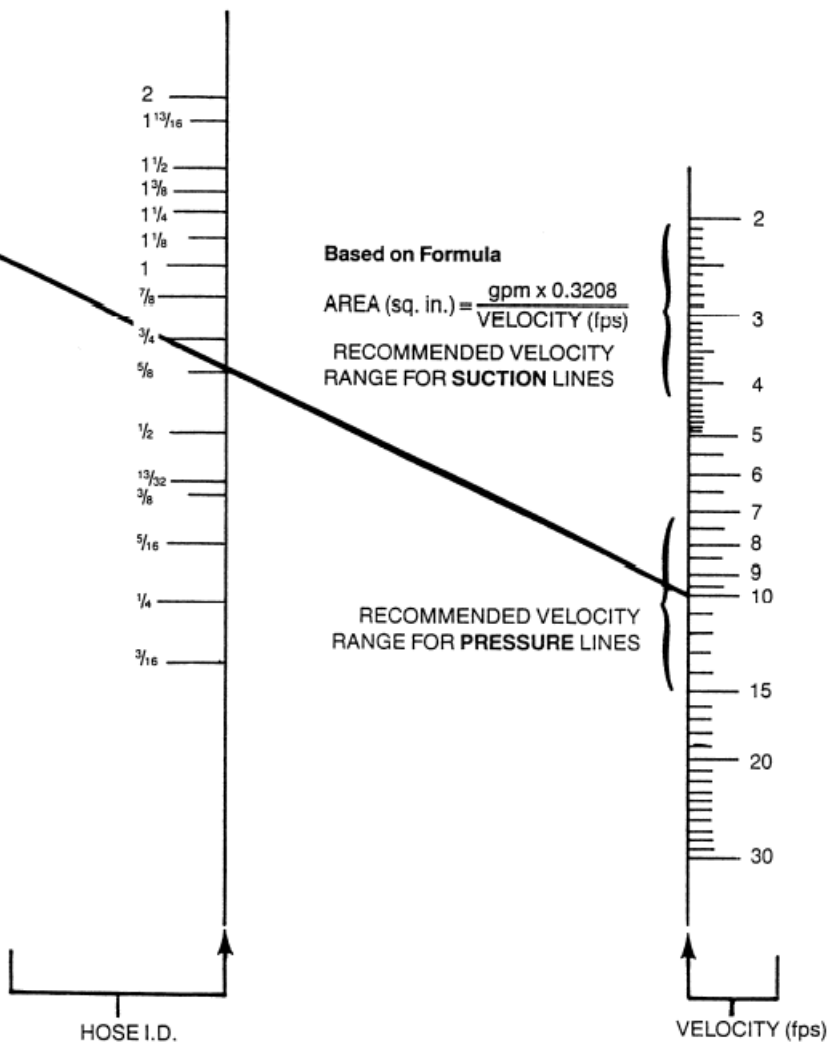

SAE SPECIFICATIONS

MAY 86 SAE Recommended Practice Report of the Fluid Conductors and Connectors Technical Committee, approved September 1979 and reaffirmed May 1986

1. Scope- Hose (also includes hose assemblies) has a finite life and there are a number of factors which will reduce its life. This recommended practice is intended as a guide to assist system designers and/or users in the selection, installation, and maintenance of hose. The designers and users must make a systematic review of each application and then select, install, and maintain the hose to fulfill the requirements of the application. The following are general guidelines and are not necessarily a complete list. **WARNING: IMPROPER SELECTION, INSTALLATION, OR MAINTENANCE MAY RESULT IN PREMATURE FAILURES, BODILY INJURY, OR PROPERTY DAMAGE.**

2. Selection- The following is a list of factors which must be considered before final hose selection can be made:

2.1 Pressure - After determining the system pressure, hose selection must be made so that the recommended maximum operating pressure is equal to or greater than the system pressure. Surge pressures higher than the maximum operating pressure will shorten hose life and must be taken into account by the hydraulic designer.

2.2 Suction - Hoses used for suction applications must be selected to insure the hose will withstand the negative pressure of the system.

2.3 Temperature - Care must be taken to insure that fluid and ambient temperatures, both static and transient, do not exceed the limitations of the hose. Special care must be taken when routing near hot manifolds.

2.4 Fluid Compatibility - Hose selection must assure compatibility of the hose tube, cover, and fittings with the fluid used. Additional caution must be observed in hose selection for gaseous applications.

2.5 Size - Transmission of power by means of pressurized fluid varies with pressure and rate of flow. The size of the components must be adequate to keep pressure losses to a minimum and avoid damage to the hose due to heat generation or excessive turbulence.

2.6 Routing - Attention must be given to optimum routing to minimize inherent problems.

2.7 Environment - Care must be taken to insure that the hose and fittings are either compatible with or protected from the environment to which they are exposed. Environmental conditions such as ultraviolet light, ozone, salt water, chemicals, and air pollutants can cause degradation and premature failure and, therefore, must be considered.

2.8 Mechanical Loads - External forces can significantly reduce hose life. Mechanical loads which must be considered include excessive flexing, twist, kinking, tensile or side loads, bend radius, and vibration. Use of swivel type fittings or adapters may be required to insure no twist is put into the hose. Unusual applications may require special testing prior to hose selection.

2.9 Abrasion - While a hose is designed with a reasonable level of abrasion resistance, care must be taken to protect the hose from excessive abrasion which can result in erosion, snagging, and cutting of the hose cover. Exposure of the reinforcement will significantly accelerate hose failure.

2.10 Proper End Fitting - Care must be taken to insure proper compatibility exists between the hose and coupling selected based on the manufacturer's recommendations substantiated by testing to industry standards such as SAE J517d (November, 1976).

2.11 Length - When establishing proper hose length, motion absorption, hose length changes due to pressure, as well as hose and machine tolerances must be considered.

2.12 Specifications and Standards - When selecting hose, government, industry, and manufacturers specifications and recommendations must be reviewed as applicable.

2.13 Hose Cleanliness - Hose components vary in cleanliness levels. Care must be taken to insure that the assemblies selected have an adequate level of cleanliness for the application.

2.14 Electrical Conductivity - Certain applications require that hose be nonconductive to prevent electrical current flow. Other applications require the hose to be sufficiently conductive to drain off static electricity. Hose and fittings must be chosen with these needs in mind.

3. Installation - After selection of proper hose, the following factors must be considered by the installer:

3.1 Pre-Installation Inspection - Prior to installation, a careful examination of the hose must be performed. All components must be checked for correct style, size, and length. In addition, the hose must be examined for cleanliness, I.D. obstructions, blisters, loose cover, or any other visible defects.

3.2 Follow Manufacturers' Assembly Instructions

3.3 Minimum Bend Radius - Installation at less than minimum bend radius may significantly reduce hose life. Particular attention must be given to preclude sharp bending at the hose/fitting juncture.

3.4 Twist Angle and Orientation - Hose installations must be such that relative motion of machine components produces bending of the hose rather than twisting.

3.5 Securement - In many applications, it may be necessary to restrain, protect, or guide the hose to protect it from damage by unnecessary flexing, pressure surges, and contact with other mechanical components. Care must be taken to insure such restraints do not introduce additional stress or wear points.

3.6 Proper Connection of Ports - Proper physical installation of the hose requires a correctly installed port connection while insuring that no twist or torque is put into the hose.

3.7 Avoid External Damage - Proper installation is not complete without insuring that tensile loads, side loads, kinking, flattening, potential abrasion, thread damage, or damage to sealing surfaces are corrected or eliminated.

3.8 System Check Out - After completing the installation, all air entrapment must be eliminated and the system pressurized to the maximum system pressure and checked for proper function and freedom from leaks.

NOTE: Avoid potential hazardous areas while testing.

4. Maintenance - Even with proper selection and installation, hose life may be significantly reduced without a continuing maintenance program. Frequency should be determined by the severity of the application and risk potential. A maintenance program should include the following as a minimum:

4.1 Hose Storage - Hose products in storage can be affected adversely by temperature, humidity, ozone, sunlight, oils, solvents, corrosive liquids and fumes, insects, rodents, and radioactive materials. Storage areas should be relatively cool and dark and free of dust, dirt, dampness, and mildew.

4.2 Visual Inspections - Any of the following conditions requires replacement of the hose:

- (a) Leaks at fitting or in hose. (Leaking fluid is a fire hazard.)
- (b) Damaged, cut, or abraded cover. (Any reinforcement exposed.)
- (c) Kinked, crushed, flattened, or twisted hose.
- (d) Hard, stiff, heat cracked, or charred hose.
- (e) Blistered, soft, degraded, or loose cover.
- (f) Cracked, damaged, or badly corroded fittings.
- (g) Fitting slippage on hose.

4.3 Visual Inspections - The following items must be tightened, repaired, or replaced as required:

- (h) Leaking port conditions.
- (i) Clamps, guards, shields.
- (j) Remove excessive dirt buildup.
- (k) System fluid level, fluid type, and any air entrapment.

4.4 Functional Test - Operate the system at maximum operating pressure and check for possible malfunctions and freedom from leaks.

NOTE: Avoid potential hazardous areas while testing.

4.5 Replacement Intervals - Specific replacement intervals must be considered based on previous service life, government or industry recommendations, or when failures could result in unacceptable down time, damage, or injury risk.

NATIONAL HOSE

HOSE INSTALLATION TIPS

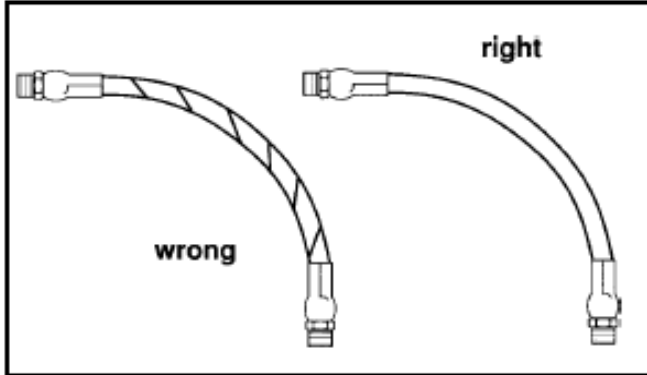

1. Hose is weakened when installed in twisted position. Pressure in twisted hose tends to loosen fitting connections. Design so that machine motion produces bending rather than twisting.

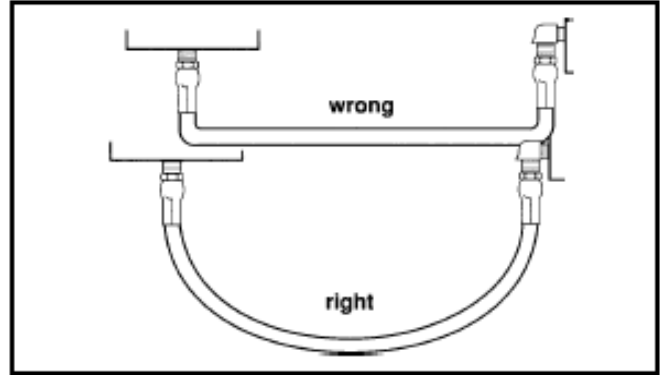

2. Ample bend radius should be provided to avoid collapsing of line and restriction of flow.

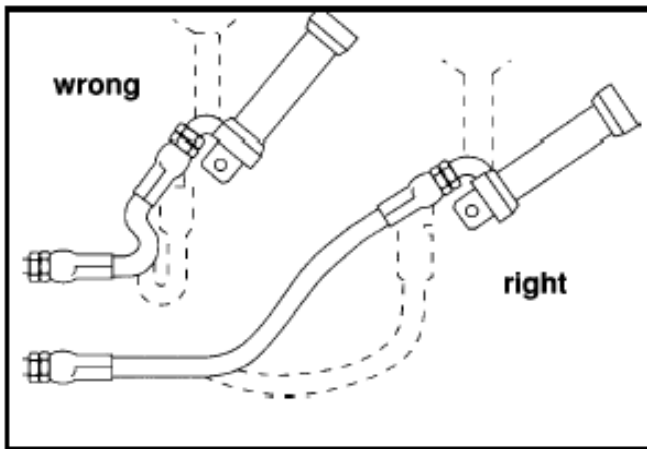

3. Exceeding minimum bend radius will greatly reduce hose assembly life.

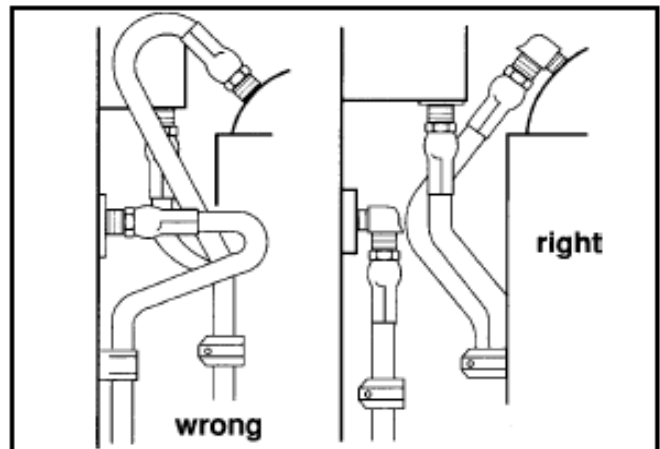

4. Use elbows or other adapters as necessary to eliminate excess hose length and to insure neater installation for easier maintenance.

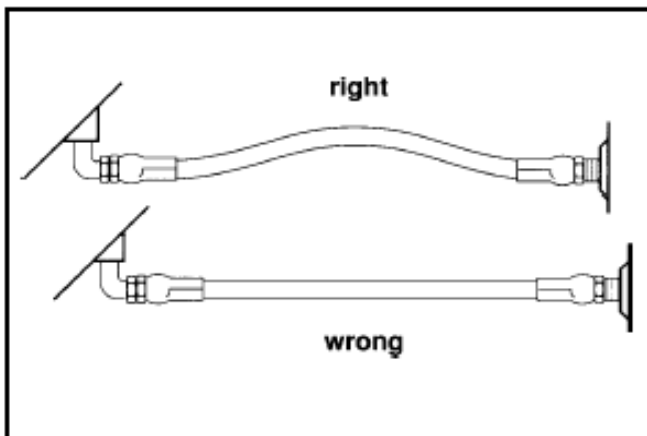

5. When hose assembly is installed in a flexing application, remember that metal hose fittings are not part of the flexible portion. Allow ample free length for flexing.

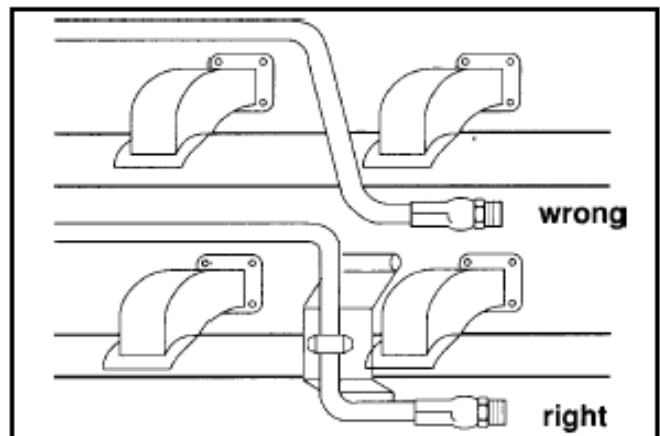

6. When properly routing, use clamps to secure the hose in its proper position.

NATIONAL HOSE

S.T.A.M.P.E.D *HOSE & ASSEMBLY REQUEST FORM*

SIZE	I.D.	O.D.	Overall Length	Tolerance
	inch / mm	inch / mm	Ft / Inch. - Met / mm	+/-

Temperature	Material Conveyed	Environmental Temperature
	Min & Max	Min & Max
	°F or °C	°F or °C

Application	Type of Service for Hose or Assembly

Material / Media	Material Conveyed	
	Internal Media	External Environment

Pressure	Max Working Pressure	Spikes	Vacuum
	PSI or kPa	PSI or kPa	inch of Hg

Ends	Ends	Style	Orientation	Attachment	Assembly or Hose
	Size	Material		Methods	Ends to be Capped
	1)				YES or NO
2)					YES or NO

Delivery	Quantity Required:		Date Required:
	Package Type:		
	Pick Up Date:		Ship Via:
	Testing Required:	Yes or No →	Type:
	Certification Required:	Yes or No →	Type:

Special Requirements or Request:

NATIONAL HOSE

THREAD STANDARDS Quick Reference Chart

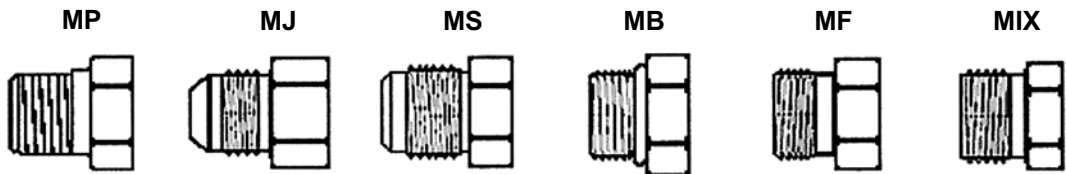

DASH SIZE	FRACTION In 1/16ths	NPTF or PIPE	SAE / JIC 37° FLARE	SAE 45° FLARE	O-RING BOSS	O-RING FACE SEAL	INVERTED FLARE
-2	1/8"	1/8"-27	5/16"-24	5/16"-24	5/16"-24	-	5/16"-18
-3	3/16"	-	3/8"-24	3/8"-24	3/8"-24	-	3/8"-24
-4	1/4"	1/4"-18	7/16"-20	7/16"-20	7/16"-20	9/16"-18	7/16"-24
-5	5/16"	-	1/2"-20	1/2"-20	1/2"-20	-	1/2"-20
-6	3/8"	3/8"-18	9/16"-18	-	9/16"-18	11/16"-16	5/8"-18
-7	-	-	-	11/16"-16	-	-	11/16"-18
-8	1/2"	1/2"-14	3/4"-16	3/4"-16	3/4"-16	13/16"-16	3/4"-18
-10	5/8"	-	7/8"-14	7/8"-14	7/8"-14	1"-14	7/8"-18
-12	3/4"	3/4"-14	1-1/16"-12	1-1/16"-14	1-1/16"-12	1-3/16"-12	1-1/16"-16
-14	7/8"	-	1-3/16"-12	-	1-3/16"-12	-	1-3/16"-16
-16	1"	1"-11 1/2	1-5/16"-12	-	1-5/16"-12	1-7/16"-12	1-5/16"-16
-20	1-1/4"	1-1/4"-11 1/2	1-5/8"-12	-	1-5/8"-12	1-11/16"-12	-
-24	1-1/2"	1-1/2"-11 1/2	1-7/8"-12	-	1-7/8"-12	2"-12	-
-32	2"	2"-11 1/2	2-1/2"-12	-	2-1/2"-12	-	-
-40	2-1/2"	2-1/2"-8	3"-12	-	-	-	-
-48	3"	3"-8	3-1/2"-12	-	-	-	-

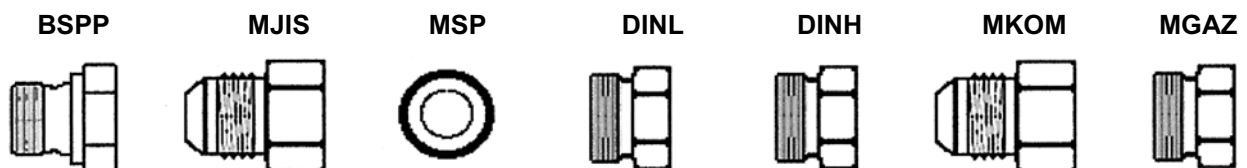

DASH SIZE	BSP BRITISH	JIS 30° BRITISH	Tube O.D METRIC	DIN "L" METRIC	DIN "S" METRIC	JIS 30° METRIC	GAZ METRIC
-2	1/8"-28	-	6mm	M12 x 1.5	M14 x 1.5	-	-
-3	-	-	8mm	M14 x 1.5	M16 x 1.5	-	-
-4	1/4"-19	1/4"-19	10mm	M16 x 1.5	M18 x 1.5	M14 x 1.5	-
-5	-	-	12mm	M18 x 1.5	M20 x 1.5	M16 x 1.5	M20 x 1.5
-6	3/8"-19	3/8"-19	14mm	-	M22 x 1.5	M18 x 1.5	M20 x 1.5
-7	-	-	15mm	M22 x 1.5	-	-	-
-8	1/2"-14	1/2"-14	16mm	-	M24 x 1.5	M22 x 1.5	M24 x 1.5
-10	5/8"-14	-	18mm	M26 x 1.5	-	M24 x 1.5	M30 x 1.5
-12	3/4"-14	3/4"-14	20mm	-	M30 x 2	M28 x 1.5	M36 x 1.5
-14	-	-	22mm	M30 x 2	-	M30 x 1.5	-
-16	1"-11	1"-11	25mm	-	M36 x 2	M33 x 1.5	M45 x 1.5
-20	1-1/4"-11	1-1/4"-11	28mm	M36 x 2	-	M36 X 1.5	-
-24	1-1/2"-11	-	30mm	-	M42 x 2	M42 X 1.5	-
-32	2"-11	-	35mm	M45 x 2	-	-	-
-40	-	-	38mm	-	M52 x 2	-	-
-48	-	-	42mm	M52 x 2	-	-	-

NATIONAL HOSE

THREAD STANDARDS

Dash Numbers:

Most fluid piping systems sizes are measured by dash numbers. These are universally used abbreviations for the size of a component expressed as the numerator of the fraction with the denominator always being 16. For example a -4 or -04 port is 4/16 or 1/4 inch. Dash numbers are usually nominal (In name only) and are abbreviations that make ordering of components easier. There are few coupling systems used for hydraulic connections. They are identified as:

American, British, German, Japanese, French. This section lists the origin & coupling style as well as. Descriptions and dimensional data to follow each coupling style.

American Thread Styles

NPTF - National Pipe Tapered Fuel

This is a dryseal thread, the National pipe tapered thread for fuels. This is used for both male & female ends. This connection is still widely used in fluid power systems, even though it is not recommended by the **(N.F.P.A)** National Fluid Power Association for use in hydraulic applications.

The **NPTF** male will mate or connect with **NPTF, NPSF, & NPSM** female connections.

The NPTF male has tapered threads and a 30° chamfer or inverted seat. The NPTF female has tapered threads and no seat. The seal takes place by the crushing or deformation of the threads. The NPSM female has straight threads and a tapered 30° ball cone seat. The seal takes place with the 30° chamfer of the male NPTF & the 30° taper of the ball cone of the NPSM swivel. The **NPTF** connection is similar to but **not interchangeable** with the **BSPT** connection. The thread pitch is different in most sizes. Also, the thread angle is 60° on the NPTF instead of the 55° angle found on the BSPT threads.

NPSF - National Pipe Straight Thread for Fuels

National pipe straight thread for fuels. This is sometimes used for female ends & properly mates or connects with the NPTF male end. However, the SAE recommends the NPTF female thread in preference to the NPSF for female ends.

NPSM - National Pipe Straight or Swivel Mechanical

National pipe straight thread for mechanical joint seal. This is used on the female swivel nut of pipe swivel adapters and hose fittings. The leak-resistant joint is not made by the crushing or deformation of threads, but by the tapered 30° ball cone seat in the coupling end. This connection is sometimes used in fluid power systems.

Thread Identification Chart National Pipe Tapered for Fuels - NPTF National Pipe Straight Mechanical - NPSM

Dash Size	Inch Size	Thread Size (inch - TPI)	Female Thread I.D.		Male Thread O.D.	
			inch	mm	inch	mm
-2	1/8"	1/8"-27	0.34	8.7	0.41	10.3
-4	1/4"	1/4"-18	0.47	11.9	0.56	14.3
-6	3/8"	3/8"-18	0.59	15.1	0.69	17.5
-8	1/2"	1/2"-14	0.72	18.3	0.84	21.4
-12	3/4"	3/4"-14	0.94	23.8	1.06	27.0
-16	1"	1"-11 1/2	1.19	30.2	1.31	33.3
-20	1-1/4"	1-1/4"-11 1/2	1.53	38.9	1.69	42.9
-24	1-1/2"	1-1/2"-11 1/2	1.75	44.5	1.91	48.4
-32	2"	2"-11 1/2	2.25	57.2	2.38	60.3

NATIONAL HOSE

THREAD STANDARDS

37° SEAT (JIC) - SAE J514

The Society of Automotive Engineers (SAE) specifies a 37° angle flare or seat with high pressure hydraulic tubing. These are commonly JIC couplings. The JIC 37° flare male will mate or connect with a JIC female only. The JIC male has straight threads and a 37° flare or cone seat. The JIC female also has straight threads and a 37° flare or cone seat. The seat is made on the 37° flare seat by establishing a line of contact between the male flare and the female flare cone seat. The threads hold the connection mechanically together. **CAUTION:** In the **-2, -3, -4, -5, -8, & -10 sizes**, the threads of the SAE 45° flare & JIC 37° flare are the same. However the sealing surface angles are NOT the same. Carefully measure the seat angle to differentiate.

**Thread Identification Chart
JIC 37° Flare Seat - SAE J514**

Dash Size	Inch Size	Thread Size (inch - TPI)	Female Thread I.D.		Male Thread O.D.	
			inch	mm	inch	mm
-2*	1/8"	5/16"-24	0.27	6.9	0.31	7.8
-3*	3/16"	3/8"-24	0.34	8.5	0.37	9.4
-4*	1/4"	7/16"-20	0.39	9.9	0.44	11.2
-5*	5/16"	1/2"-20	0.45	11.5	0.49	12.6
-6	3/8"	9/16"-18	0.51	12.9	0.56	14.1
-8*	1/2"	3/4"-16	0.69	17.5	0.74	18.9
-10*	5/8"	7/8"-14	0.81	20.5	0.87	22.1
-12	3/4"	1-1/16"-12	0.98	24.9	1.06	26.9
-14	7/8"	1-3/16"-12	1.11	28.1	1.18	30.0
-16	1"	1-5/16"-12	1.23	31.3	1.31	33.1
-20	1-1/4"	1-5/8"-12	1.54	39.2	1.62	41.1
-24	1-1/2"	1-7/8"-12	1.79	45.6	1.87	47.4
-32	2"	2-1/2"-12	2.42	61.4	2.49	63.3

45° SEAT (SAE) - SAE J512

A term usually applied to fittings having a 45° angle flare or seat. Soft copper tubing is generally used in such applications as it is easily flared to the 45° angle. These are for low pressure applications-commonly used in refrigeration, automotive and truck piping systems. The Sae 45° flare male will mate or connect with the Sae 45° flare female only. The Sae male has straight threads and a 45° flare or cone seat. The Sae female also has straight threads and a 45° flare or cone seat. The seat is made by establishing a line of contact between the male flare and female flare cone seat. The threads hold the connection together mechanically together. **CAUTION:** In the **-2, -3, -4, -5, -8, & -10 sizes**, the threads of the SAE 45° flare & JIC 37° flare are the same. However the sealing surface angles are NOT the same. Carefully measure the seat angle to differentiate.

**Thread Identification Chart
SAE 45° Flare Seat - SAE J512**

Dash Size	Inch Size	Thread Size (inch - TPI)	Female Thread I.D.		Male Thread O.D.	
			inch	mm	inch	mm
-2*	1/8"	5/16"-24	0.27	6.9	0.31	7.9
-3*	3/16"	3/8"-24	0.34	8.6	0.38	9.6
-4*	1/4"	7/16"-20	0.39	9.9	0.44	11.2
-5*	5/16"	1/2"-20	0.45	11.4	0.50	12.7
-6	3/8"	5/8"-18	0.56	14.2	0.62	15.7
-7	7/16"	11/16"-16	0.62	15.7	0.68	17.3
-8*	1/2"	3/4"-16	0.68	17.0	0.75	19.0
-10*	5/8"	7/8"-14	0.80	20.3	0.88	22.3
-12	3/4"	1-1/16"-14	0.99	25.1	1.06	26.9
-14	7/8"	1-1/4"-12	1.16	29.5	1.25	31.7
-16	1"	1-3/8"-12	1.28	32.5	1.38	35.0

NATIONAL HOSE

THREAD STANDARDS

O-RING BOSS

STRAIGHT THREAD - SAE J514

This port connection is recommended by the **N.F.P.A.** (National Fluid Power Association) for optional leakage control in medium and high pressure hydraulic systems. The O-ring boss male will mate with an O-ring boss female only. The female is generally found on ports. The male has straight threads and an O-ring. The female also has straight threads and a sealing face or chamfer. The seal is made at the O-ring on the male and the sealing face of the female. The threads hold the connection together & the O-ring forms the seal.

Thread Identification Chart
O-Ring Boss Straight Thread - SAE J514

Dash Size	Inch Size	Thread Size (inch - TPI)	Female Thread I.D.		Male Thread O.D.	
			inch	mm	inch	mm
-2	1/8"	5/16"-24	0.27	6.9	0.31	7.8
-3	3/16"	3/8"-24	0.34	8.5	0.37	9.4
-4	1/4"	7/16"-20	0.39	9.9	0.44	11.2
-5	5/16"	1/2"-20	0.45	11.5	0.49	12.6
-6	3/8"	9/16"-18	0.51	12.9	0.56	14.1
-8	1/2"	3/4"-16	0.69	17.5	0.74	18.9
-10	5/8"	7/8"-14	0.81	20.5	0.87	22.1
-12	3/4"	1-1/16"-12	0.98	24.9	1.06	26.9
-14	7/8"	1-3/16"-12	1.11	28.1	1.18	30.0
-16	1"	1-5/16"-12	1.23	31.3	1.31	33.1
-20	1-1/4"	1-5/8"-12	1.54	39.2	1.62	41.1
-24	1-1/2"	1-7/8"-12	1.79	45.6	1.87	47.4
-32	2"	2-1/2"-12	2.42	61.4	2.49	63.3

O-RING FACE SEAL

SAE J1453

The seal is made when the O-ring in the male contacts the flat face of the female. These couplings are intended for hydraulic systems where elastomeric seals or (O-rings) are acceptable to overcome leakage & leak resistance is crucial. This connection offers the very best leakage control available today. The male connector has a straight thread and a machine groove flat face. The female also has straight threads and a complete flat face (no groove on the female end) The seal takes place as the male O-ring face seal is compressing the O-ring onto the flat face of the female O-ring face seal end.

This is similar to the split flange style fitting connections. The threads hold the connection mechanically together as the O-ring forms the seal.

Thread Identification Chart
O-Ring Face Seal - SAE J1453

Dash Size	Inch Size	Thread Size (inch - TPI)	Female Thread I.D.		Male Thread O.D.	
			inch	mm	inch	mm
-4	1/4"	9/16"-18	0.51	12.9	0.56	14.2
-6	3/8"	11/16"-16	0.63	16.0	0.68	17.3
-8	1/2"	13/16"-16	0.75	19.0	0.81	20.6
-10	5/8"	1"-14	0.93	23.6	1.00	25.4
-12	3/4"	1-3/16"-12	1.10	27.8	1.18	30.0
-16	1"	1-7/16"-12	1.36	34.5	1.44	36.6
-20	1-1/4"	1-11/16"-12	1.60	40.6	1.68	42.7
-24	1-1/2"	2"-12	1.92	48.8	2.00	50.8

NATIONAL HOSE

THREAD STANDARDS

O-RING FLANGE Code 61 & 62 - SAE J518

This connection is commonly used in fluid power systems. There are two pressure ratings **Code 61** "standard" 3000 psi series and **Code 62** "heavy duty" 6000 psi series. The design concept for both the Code 61 & 62 series connections is the same but the bolt hole spacing and flange head diameters are different. The larger flange head Code 62 Series is for higher pressures. The female (port) is an unthreaded hole with four bolt holes in a rectangular pattern around the port. The male consists of a flange head & machined groove for an O-ring and either split flange halves or a captive flange with bolt holes to match the female port. The seal takes place on the O-ring, which is compressed between the male flange head and the female flat surface surrounding the port. The threaded bolts & lock washers hold the connection together as the O-ring forms the seal.

Flange Identification Chart & Pressure Ratings **Sae Code 61 & Code 62 Flange Heads & Thickness** **Caterpillar Code 62 Flange Heads & Thickness**

Dash Size	Code 61 Flange O.D.		Code 61 Flange Thickness		Code 62 Flange O.D.		Code 62 Flange Thickness		Caterpillar Flange O.D.		Caterpillar Flange Thickness	
	inch	mm	inch	mm	inch	mm	inch	mm	inch	mm	inch	mm
-8	1.19	30.2	0.265	6.7	1.25	31.8	0.305	7.7				
-10*	1.34	34.0	0.265	6.7								
-12	1.50	38.1	0.265	6.7	1.63	41.3	0.345	8.7	1.63	41.3	0.56	14.2
-16	1.75	44.5	0.315	8.0	1.88	47.6	0.375	9.5	1.88	47.6	0.56	14.2
-20	2.00	50.8	0.315	8.0	2.13	54.0	0.405	10.3	2.13	54.0	0.56	14.2
-24	2.38	60.3	0.315	8.0	2.50	63.5	0.495	12.6	2.50	63.5	0.56	14.2
-32	2.81	71.4	0.375	9.5	3.13	79.4	0.495	12.6	3.13	79.4	0.56	14.2
-40	3.31	84.1	0.375	9.5								
-48	4.00	101.6	0.375	9.5								

* SAE J518, DIN 20066, ISO/DIS 6162 & JIS B 8363 Are Interchangeable, Except For Bolt Sizes

* All Code 61 Flange head hose couplings meet or exceed SAE J518 Code 61 requirements for hydraulic split flange connections. The code 61 flange head design can withstand a maximum operating pressure of 3000 to 5000 psi depending on the size. Code 62 flanges withstand a maximum operating pressures of 6000 psi in all sizes.

HOW TO MEASURE- FOUR BOLT FLANGES

First measure the port hole diameter using a caliper. Next, measure the longest bolt hole spacing from center - to - center & then the shortest bolt hole spacing from center - to - center, please feel free to ask us for more information on hydraulic flanges for your quick reference.

HOW TO MEASURE- FLANGE HEADS ON HOSE COUPLINGS

First measure the flange head O.D. with a caliper. Then measure the flange head thickness. Then use the **Flange Identification Chart** above to confirm your flange head size.

THERE ARE THREE EXCEPTIONS

- 1) The -10 size which is common outside of North America is not an SAE standard size.
- 2) Caterpillar flanges, which have the same flange O.D. as SAE Code 62, but a thicker flange thickness.
- 3) Poclain flanges, which are completely different from SAE flanges.

NATIONAL HOSE

THREAD STANDARDS

INVERTED FLARE - SAE J512

This connection is frequently used in automotive systems. The male connector can either be a 45° flare in the hose & tube fitting form or a 42° seat in the machined adapter form. The female has a straight thread with a 42° inverted flare. The seat takes place on the flared surface. The thread holds the seal mechanically together.

Thread Identification Chart Inverted Flare - SAE J512

Dash Size	Inch Size	Thread Size (inch - TPI)	Female Thread I.D.		Male Thread O.D.	
			inch	mm	inch	mm
-2	1/8"	5/16"-28	0.27	6.9	0.31	7.9
-3	3/16"	3/8"-24	0.34	8.6	0.38	9.6
-4	1/4"	7/16"-24	0.39	9.9	0.44	11.2
-5	5/16"	1/2"-20	0.45	11.4	0.50	12.7
-6	3/8"	5/8"-18	0.56	14.2	0.62	15.7
-7	7/16"	11/16"-18	0.62	15.7	0.68	17.3
-8	1/2"	3/4"-18	0.68	17.0	0.75	19.0
-10	5/8"	7/8"-18	0.80	20.3	0.88	22.3
-12	3/4"	1-1/16"-16	0.99	25.1	1.06	26.9

BRITISH CONNECTIONS

British Standard Pipe (BSP) threads are also known as **Whitworth** threads.

BSPP - British Standard Pipe Parallel

The BSPP (parallel) male will mate or connect with a BSPP (parallel) female swivel or female port. The BSPP male has straight threads and a 30° chamfer seat. The BSPP female also has straight threads and a 30° tapered ball cone seat. The female port also has straight threads and a spotface. The seal on the port is made with a copper washer, bonded-washer, or O-ring on the male end. The BSPP (parallel) is similar to, but not interchangeable with, the NPSM connector. The thread pitch is different in most sizes, and the thread angle is 55° instead of a 60° angle found on NPSM threads. The female swivel BSPP has a tapered ball cone which seals on the chamfer of the male BSPP.

BSPT - British Standard Pipe Tapered

The BSPT (tapered) male will mate or connect with a BSPT (tapered) female, or a BSPP (parallel) female. The BSPT male has tapered threads. When mating or connecting with either the BSPT (tapered) female or the BSPP (parallel) female port, the seal is made by crushing or distorting the threads. Thread sealant is recommended. The BSPT connector is similar to but, not interchangeable with, the NPTF connector. The thread pitch is different in most sizes, and the thread angle is 55° instead of a 60° angle found on NPTF threads.

Thread Identification Chart British Standard Pipe - BSP, BSPP, BSPT

Dash Size	Inch Size	Thread Size (inch - TPI)	Female Thread I.D.		Male Thread O.D.	
			inch	mm	inch	mm
-2	1/8"	1/8"-28	0.34	8.7	0.38	9.5
-4	1/4"	1/4"-19	0.44	11.1	0.53	13.5
-6	3/8"	3/8"-19	0.59	15.1	0.66	16.7
-8	1/2"	1/2"-14	0.72	18.3	0.81	20.6
-10	5/8"	5/8"-14	0.81	20.6	0.91	23.0
-12	3/4"	3/4"-14	0.94	23.8	1.03	26.2
-16	1"	1"-11	1.19	30.2	1.31	33.3
-20	1-1/4"	1-1/4"-11	1.53	38.9	1.66	42.1
-24	1-1/2"	1-1/2"-11	1.78	45.2	1.88	47.6
-32	2"	2"-11	2.22	56.4	2.34	59.5

NATIONAL HOSE

THREAD STANDARDS

GERMAN DIN METRIC CONNECTIONS

A coupling referred to as metric usually means a DIN coupling.

Flanges are standard Code 61 or Code 62 style.

Metric Din 2353 24° Cone Seat

The DIN 24° internal Cone Seat male will mate or connect with three different female metric connections.

The male has a 24° internal cone, straight metric threads & a recessed counterbore which matches the tube O.D. used with it. The mating females may be a 24° ball cone with an O-ring on the cone or a metric tube fitting nut or a universal 24°/60° hard nose ball cone. There is a light " L " series coupling & a heavy " S " Series DIN coupling. Proper identification is made by measuring both thread size and tube O.D. (The heavy series has a smaller tube O.D. than the light series, but the heavy series has a thicker wall thickness on the tube).

Thread Identification Chart
Metric Din 2353 24° Cone seat

Metric Thread	Metric Tube O.D.				Female Thread I.D.		Male Thread O.D.	
	Light Series		Heavy Series		mm	inch	mm	inch
Dia x Pitch	mm	Series	mm	Series				
M12x1.5	6	L6			10.5	0.41	12	0.47
M14x1.5	8	L8	6	S6	12.5	0.49	14	0.55
M16x1.5	10	L10	8	S8	14.5	0.57	16	0.63
M18x1.5	12	L12	10	S10	16.5	0.65	18	0.71
M20x1.5			12	S12	18.5	0.73	20	0.79
M22x1.5	15	L15	14	S14	20.5	0.81	22	0.87
M24x1.5			16	S16	22.5	0.89	24	0.94
M26x1.5	18	L18			24.5	0.96	26	1.02
M30x2.0	22	L22	20	S20	27.9	1.10	30	1.18
M36x2.0	28	L28	25	S25	33.9	1.33	36	1.42
M42x2.0			30	S30	39.9	1.57	42	1.65
M45x2.0	35	L35			42.9	1.69	45	1.77
M52x2.0	42	L42	38	S38	49.9	1.96	52	2.05

Metric Din 3863 60° Cone Seat

This connection is frequently used in hydraulic systems. The DIN 60° internal cone male thread will mate or connect with the a female universal 24°/60° cone only. The male has a 60° internal cone & straight metric threads. The female has a 24° & 60° universal ball cone seat also with straight metric threads. The seal takes place by contact between the internal cone of the male and the ball cone of the female swivel. The threads hold the connection mechanically together.

Thread Identification Chart
Metric Din 3863 60° Cone seat

Metric Thread	Metric Tube O.D. 60° Cone		Female Thread I.D.		Male Thread O.D.	
	mm	inch	mm	inch	mm	inch
Dia x Pitch						
M12x1.5	6	0.24	10.5	0.41	12	0.47
M14x1.5	8	0.31	12.5	0.49	14	0.55
M16x1.5	10	0.39	14.5	0.57	16	0.63
M18x1.5	12	0.47	16.5	0.65	18	0.71
M22x1.5	15	0.59	20.5	0.81	22	0.87
M26x1.5	18	0.71	24.5	0.96	26	1.02
M30x1.5	22	0.87	28.5	1.12	30	1.18
M38x1.5	28	1.10	36.5	1.44	38	1.50
M45x1.5	35	1.38	43.5	1.71	45	1.77
M52x1.5	42	1.65	50.5	1.99	52	2.05

NATIONAL HOSE

THREAD STANDARDS

FRENCH METRIC CONNECTIONS

A coupling referred to as french metric usually means a GAZ coupling.

French Metric Gaz 24° Cone Seat

This connection is only found on french made equipment. The GAZ 24° internal cone male thread will mate or connect with only two female connections. The 24° female bite type tube, nut, & sleeve or the 24°/60° female universal ball cone seat.

Thread Identification Chart French Metric Gaz 24° Cone seat

Metric Thread	Metric Tube O.D. 24° Cone		Female Thread I.D.		Male Thread O.D.	
	mm	inch	mm	inch	mm	inch
Dia x Pitch						
M20x1.5	13.25	0.52	18.5	0.73	20	0.78
M24x1.5	16.75	0.66	22.5	0.89	24	0.94
M30x1.5	21.25	0.83	28.5	1.12	30	1.18
M36x1.5	26.75	1.05	34.5	1.36	36	1.41
M45x1.5	33.50	1.32	43.5	1.71	45	1.77
M52x1.5	42.25	1.66	50.5	1.99	52	2.04

JAPANESE CONNECTIONS

Japanese equipment uses. JIS (Japanese Industrial Standard) couplings with a 30° seat and British Standard Pipe Threads. Flanges are standard Code 61 or Code 62 (except -10)

JIS 30° Flare BSPP - JIS B 0202

These JIS 30° flare male couplings with Bsp threads will mate or connect with a JIS 30° flare female swivel with Bsp threads only. The male and female have straight Bsp threads and a 30° flare seat. The seal is made on the 30° flare seat. The threads on the JIS 30° flare with Bsp thread conform to JIS B 0202, both the British & Japanese connections have a 30° seat. But they are not interchangeable, because the British BSPP male has a chamfer and not the 30° male cone needed to make the seal with the female JIS coupling.

Thread Identification Chart JIS 30° Flare Bsp - JIS B 0202 JIS BSPT Tapered Pipe - JIS B 0203

Dash Size	Inch Size	Thread Size (inch - TPI)	Female Thread I.D.		Male Thread O.D.	
			inch	mm	inch	mm
-2	1/8"	1/8"-28	0.34	8.7	0.38	9.5
-4	1/4"	1/4"-19	0.47	11.9	0.53	13.5
-6	3/8"	3/8"-19	0.59	15.1	0.66	16.7
-8	1/2"	1/2"-14	0.75	19.1	0.81	20.6
-10*	5/8"	5/8"-14	0.81	20.6	0.91	23.1
-12	3/4"	3/4"-14	0.94	23.8	1.03	26.2
-16	1"	1"-11	1.19	30.2	1.31	33.3
-20	1-1/4"	1-1/4"-11	1.53	38.9	1.66	42.1
-24	1-1/2"	1-1/2"-11	1.78	45.2	1.88	47.6
-32	2"	2"-11	2.22	56.4	2.34	59.5

JIS Tapered Pipe BSPT - JIS B 0203

The JIS tapered pipe thread connection is similar to the BSPT connection and is also fully interchangeable. The Japanese BSPT does not have a 30° flare and will not mate with the BSPP female swivel. These conform to JIS B 0203 same as the BSPT threads. The seal takes place by the crushing or deformation of the threads.

NATIONAL HOSE

THREAD STANDARDS

KOMATSU JIS 30° Flare Metric - JIS B 0207

The komatsu style 30° Flare Parallel thread is identical to the Japanese 30° Flare except for the threads. The Komatsu uses Metric fine threads which conform to JIS B 0207. The Komatsu seal is made by the 30° cone seats.

Thread Identification Chart Komatsu JIS 30° Flare Metric - JIS B 0207

Dash Size	Inch Size	Thread Size	Female Thread I.D.		Male Thread O.D.	
			mm	inch	mm	inch
-6	3/8"	M18x1.5	16.4	0.65	18	0.71
-8	1/2"	M22x1.5	20.4	0.82	22	0.87
-10	5/8"	M24x1.5	22.4	0.88	24	0.94
-12	3/4"	M30x1.5	28.4	1.12	30	1.18
-16	1"	M33x1.5	31.4	1.24	33	1.30
-20	1-1/4"	M36x1.5	34.4	1.36	36	1.42
-24	1-1/2"	M42x1.5	40.4	1.59	42	1.65

KOMATSU O-RING FLANGES

The Komatsu style Flange is nearly identical to and fully interchangeable with SAE Code 61 flange heads. In all sizes the O-ring dimensions are different. When replacing a Komatsu flange with an SAE style flange, you must use the SAE style O-ring only.

Flange Identification Chart Komatsu O-ring Flange Heads - Code 61 Style

Dash Size	Komatsu Flange O.D.		Komatsu Flange Thickness		Komatsu O-Ring Sizes	
	inch	mm	inch	mm	I.D.	O.D.
-8	1.19	30.2	0.265	6.7	0.73	0.98
-10*	1.34	34.0	0.265	6.7	0.73	1.10
-12	1.50	38.1	0.265	6.7	0.85	1.22
-16	1.75	44.5	0.315	8.0	1.12	1.50
-20	2.00	50.8	0.315	8.0	1.36	1.73
-24	2.38	60.3	0.315	8.0	1.75	2.12
-32	2.81	71.4	0.375	9.5	2.22	2.56

NATIONAL HOSE

End Style Designation Charts For New National Hose To Old Dayco Eastman Series Connections

National Hose	Dayco Eastman	DESCRIPTIONS (Terminations are For Threads & End Connections)
BFPX	BPHB	Female Swivel British O-ring Face Seal Straight - (BSPP Thread)
BSPP	BP	Male Rigid British Standard Parallel Pipe Straight - (BSPP Thread)
BSPT	BT	Male Rigid British Standard Pipe Tapered - (BSPT Thread)
BSPX	BPF	Female Swivel British Standard Parallel Pipe Straight - (BSPP Thread)
BSPX45	BPF45T	Female Swivel British Standard Parallel Pipe 45° Bent Tube - (BSPP Thread)
BSPX90	BPF90T	Female Swivel British Standard Parallel Pipe 90° Bent Tube - (BSPP Thread)
C61	PA	O-Ring Flange Straight - (SAE Code 61)
C61-22	PA22	O-Ring Flange 22.5° Bent Tube - (SAE Code 61)
C61-30	PA30	O-Ring Flange 30° Bent Tube - (SAE Code 61)
C61-45	PA45	O-Ring Flange 45° Bent Tube - (SAE Code 61)
C61-60	PA60	O-Ring Flange 60° Bent Tube - (SAE Code 61)
C61-90	PA90	O-Ring Flange 90° Bent Tube - (SAE Code 61)
C62	PH	O-Ring Flange Straight - (SAE Code 62)
C62-22	PH22	O-Ring Flange 22.5° Bent Tube - (SAE Code 62)
C62-30	PH30	O-Ring Flange 30° Bent Tube - (SAE Code 62)
C62-45	PH45	O-Ring Flange 45° Bent Tube - (SAE Code 62)
C62-60	PH60	O-Ring Flange 60° Bent Tube - (SAE Code 62)
C62-90	PH90	O-Ring Flange 90° Bent Tube - (SAE Code 62)
CAT	PHC	Caterpillar Style - O-Ring Flange Straight - (SAE Code 62)*
CAT-22	PHC22	Caterpillar Style - O-Ring Flange 22.5° Bent Tube - (SAE Code 62)*
CAT-30	PHC30	Caterpillar Style - O-Ring Flange 30° Bent Tube - (SAE Code 62)*
CAT-45	PHC45	Caterpillar Style - O-Ring Flange 45° Bent Tube - (SAE Code 62)*
CAT-60	PHC60	Caterpillar Style - O-Ring Flange 60° Bent Tube - (SAE Code 62)*
CAT-67	PHC67	Caterpillar Style - O-Ring Flange 67.5° Bent Tube - (SAE Code 62)*
CAT-90	PHC90	Caterpillar Style - O-Ring Flange 90° Bent Tube - (SAE Code 62)*
D362	KA-MP	Male Rigid National Pipe Thread Fuel - (Push On Fitting Brass)
D363	KA-MA	Male Rigid SAE 45° Seat Straight - (Push On Fitting Brass)
D364	KA-FA	Female Swivel SAE 45° Seat Straight - (Push On Fitting Brass)
D365	KA-FJ	Female Swivel JIC 37° Seat Straight - (Push On Fitting Brass)
D366	KA-NG	Male Rigid Inverted Flare Straight - (Push On Fitting Brass)
D367	KA-MF	Male Swivel Inverted Flare Straight - (Push On Fitting Brass)
D368	KA-RL	Inch O.D. Standpipe Straight Tube - (Push On Fitting Brass)
D371	KA-MJ	Male Rigid JIC 37° Seat Straight - (Push On Fitting Brass)
D379	KA-RM	Hose Mender or Splicer - (Push On Fitting Brass)
DINH	MZ (Heavy)	Male Rigid Metric Universal 24°/60° Seat Straight - ("S" Style Thread)
DINHX	RU (Heavy)	Female Swivel Metric Universal 24°/60° Seat Straight - ("S" Style Nut)
DINHX45	RU45T (Heavy)	Female Swivel Metric Universal 24°/60° Seat 45° Bent Tube - ("S" Style Nut)
DINHX90	RU90T (Heavy)	Female Swivel Metric Universal 24°/60° Seat 90° Bent Tube - ("S" Style Nut)
DINL	MZ (Light)	Male Rigid Metric Universal 24°/60° Seat Straight - ("L" Style Thread)
DINLX	RU (Light)	Female Swivel Metric Universal 24°/60° Seat Straight - ("L" Style Nut)
DINLX45	RU45T (Light)	Female Swivel Metric Universal 24°/60° Seat 45° Bent Tube - ("L" Style Nut)
DINLX90	RU90T (Light)	Female Swivel Metric Universal 24°/60° Seat 90° Bent Tube - ("L" Style Nut)
DS	M-73 (Sleeve)	Metric Sleeve Fit's Over Metric O.D. StandPipe or Tubing - ("L" & "S" Style)
FFX	OFT	Female Swivel O-Ring Face Seal Straight - (OFS Thread)
FFX45	OF45T	Female Swivel O-Ring Face Seal 45° Bent Tube - (OFS Thread)
FFX90	OF90T	Female Swivel O-Ring Face Seal 90° Bent Tube - (OFS Thread)
FFX90L	OF90TL	Female Swivel O-Ring Face Seal 90° Long Bent Tube - (OFS Thread)

NATIONAL HOSE

End Style Designation Charts For New National Hose To Old Dayco Eastman Series Connections

National Hose	Dayco Eastman	DESCRIPTIONS (Terminations are rigid unless noted)
FJX	FJ	Female Swivel JIC 37° Seat Straight - (JIC/SAE Thread)
FJX45	FJ45T	Female Swivel JIC 37° Seat 45° Bent Tube - (JIC/SAE Thread)
FJX90	FJ90T	Female Swivel JIC 37° Seat 90° Bent Tube - (JIC/SAE Thread)
FJX90L	FJ90TL	Female Swivel JIC 37° Seat 90° Long Bent Tube - (JIC/SAE Thread)
FP	FF	Female Rigid National Pipe Thread Fuel - (NPTF Dryseal Thread)
FPX	FN	Female Swivel National Pipe Swivel Mechanical - (NPSM Thread)
FSX	FA	Female Swivel SAE 45° Seat Straight - (SAE Thread)
FSX45	FA45T	Female Swivel SAE 45° Seat 45° Bent Tube - (SAE Thread)
FSX90	FA90T	Female Swivel SAE 45° Seat 90° Bent Tube - (SAE Thread)
FW		Female Weld End For Tubing - (Socket Weld)
GAZX	RY	Female Swivel Metric Universal 24°/60° Seat Straight - (French GAZ Thread)
JISX	JPF	Female Swivel JIS 30° Seat Straight - (BSPP Thread)
KAR	PWM	Female Swivel Metric Pressure Wash Straight - (Karcher Thread)
KOMX	KMF	Female Swivel Komatsu JIS 30° Seat Straight - (METRIC Thread)
M	M-56 (Nut)	Female Swivel Compression Nut - (METRIC Thread)
MB	RA	Male Rigid SAE O-Ring Boss Straight - (SAE ORB Thread)
MBX	RC	Male Swivel SAE O-Ring Boss Straight - (SAE ORB Thread)
MBX90	RC90	Male Swivel SAE O-Ring Boss 90° Block Style - (SAE ORB Thread)
MF	OM	Male Rigid O-Ring Face Seal Straight - (SAE OFS Thread)
MIX	MF	Male Swivel Inverted Flare Straight - (Inverted Flare Thread)
MIX45	MF45T	Male Swivel Inverted Flare 45° Bent Tube - (Inverted Flare Thread)
MIX90	MF90T	Male Swivel Inverted Flare 90° Bent Tube - (Inverted Flare Thread)
MJ	MJ	Male Rigid JIC 37° Seat Straight - (JIC/SAE Thread)
MOR	MOR	Male Rigid Insert O-Ring Straight - (A/C Thread)
MOR45T	MOR45T	Male Rigid Insert O-Ring 45° Bent Tube - (A/C Thread)
MOR90T	MOR90T	Male Rigid Insert O-Ring 90° Bent Tube - (A/C Thread)
MP	MP	Male Rigid National Pipe Thread Fuel - (NPTF Dryseal Thread)
MPX	MS	Male Swivel National Pipe Thread Fuel - (NPTF Dryseal Thread)
MPX90	SP90	Male Swivel National Pipe Thread Fuel 90° Block Style - (NPTF Dryseal Thread)
MS	MA	Male Rigid SAE 45° Seat Straight - (SAE Thread)
MSP	RZT	Metric O.D. StandPipe Straight Tube - (Use M Style Nut & DS Style Sleeve)
MSP45	RZ45T	Metric O.D. StandPipe 45° Bent Tube - (Use M Style Nut & DS Style Sleeve)
MSP90	RZ90T	Metric O.D. StandPipe 90° Bent Tube - (Use M Style Nut & DS Style Sleeve)
MT	MV	Male Flareless Compression with Nut & Sleeve - (SAE Thread J514 Style)
MV	MV (BL series)	Male Flareless Compression with Nut & Sleeve - (A/C Style)
MW	RL	Inch O.D. StandPipe Straight Tube - (Use Style Nut & Style Sleeve)
RM	RM (BL series)	Hose Mender or Splicer - (A/C Style)
SHELL		Crimp Shell - (Only)
TF45T	TF45T	Female Swivel Tube "O-Ring" Refrigerant 45° Bent Tube - (A/C Style)
TF90T	TF90T	Female Swivel Tube "O-Ring" Refrigerant 90° Bent Tube - (A/C Style)
TFS	TFS	Female Swivel Tube "O-Ring" Refrigerant Straight - (A/C Style)
TM45T	TM45T	Male Swivel Tube "O-Ring" Refrigerant 45° Bent Tube - (A/C Style)
TM90T	TM90T	Male Swivel Tube "O-Ring" Refrigerant 90° Bent Tube - (A/C Style)
TMS	TMS	Male Swivel Tube "O-Ring" Refrigerant Straight - (A/C Style)

NATIONAL HOSE

HOW TO READ OUR PART NUMBER SYSTEM

Actual I.D. In (inches)	Standard Hose Dash Sizes	Specialty Hose R5, BH, T1,
1/8"	-2	-3
3/16"	-3	-4
1/4"	-4	-5
5/16"	-5	-6
3/8"	-6	
13/32"		-8
1/2"	-8	-10
5/8"	-10	-12
3/4"	-12	
7/8"		-14
1"	-16	
1-1/8"		-20
1-1/4"	-20	
1-3/8"		-24
1-1/2"	-24	
1-13/16"		-32
2"	-32	
2-1/2"	-40	
3"	-48	

Part Number Definition For Hose

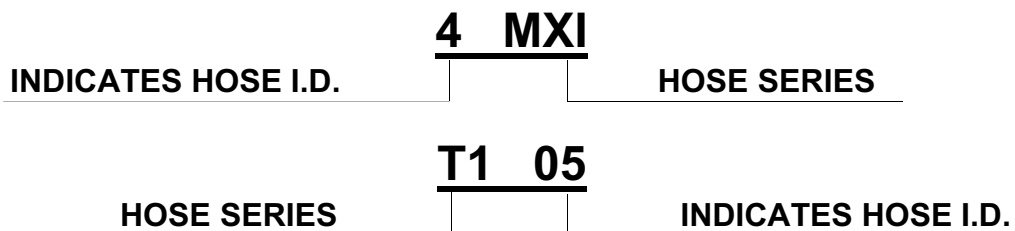

Example # 1 4MXI = 1/4" I.D. HOSE MXI SERIES
 Example # 2 T105 = 1/4" I.D. HOSE T1 SERIES

Part Number Definition For Couplings

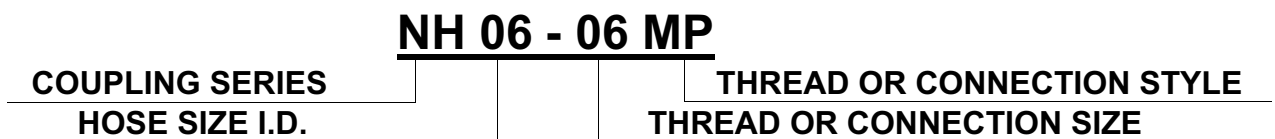

NATIONAL HOSE

HOSE SELECTION BY SIZE & PRESSURE

HOSE DASH SIZE (I.D.)

HOSE SERIES	PG #	-2	-3	-4	-5	-6	-8	-10	-12	-16	-20	-24	-32	-40	-48
4SH	35								6,100	5,516	4,720	4,210	3,625		
4SP	35					6,450	6,020	5,075							
AU-05	27			300		300	300	300	300						
AMI	24			3,000		3,000	3,000		3,000	3,000					
BH	28					350	350	350	350						
BXI	23			5,800	5,100	4,800	4,000	3,600	3,100	2,400	1,800	1,300	1,160	1,000	
CEI	35					4,000	4,000	4,000	4,000	4,000	3,000	2,500	2,500		
FXI	24			3,500		4,000	3,500		2,250	2,000					
HPS	33		3,300	3,300		3,300									
JL	25			10,000		10,000									
MXI	23				3,120	2,610	2,320	1,890	1,525	1,275	915	725	580	362	
N2I	36								6,000	6,000	6,000	6,000			
NHI	36								5,000	5,000	5,000	5,000	5,000		
PFI	25			5,800	5,100	4,800	4,000	4,000	4,000	3,600					
PFSS	32						1,500		1,100	1,000	825	750	625		
PW	26			3,000		3,000									
PW-HP	26					4,500									
R4	27								300	250	200	150	100	100	100
R5	28			3,000	3,000	2,250	2,000	1,750	1,500	800	625	500	350		
R7	29	3,400	3,100	3,000	2,800	2,750	2,450		1,500	1,350					
R7TL	30			3,000	2,800	2,750	2,450								
R8	31	7,100	5,850	5,850	5,680	5,550	3,550		2,450	2,150					
T1	32		3,000	3,000	3,000	2,500	2,000	1,500	1,200	1,000					
WB	34					18,000	16,000		12,000	10,000					

After you have determined the I.D. of the hose that is needed, locate the pressure that is required & to the left of the page you will see the hose & page number to find the hose. Turn to that page to determine if the hose meets the other criteria for use
NOTE: Please remember to consider Temperature, Fluid type, & other pressure conditions, such as Surges or Spike loads.

NATIONAL HOSE

WIRE BRAIDED HYDRAULIC HOSES

MXI SERIES

SAE 100R1AT / EN 853 1SN

Meets or Exceeds requirements of SAE 100R1AT



Application: High pressure hydraulic oils, air & water

Construction

Tube: Synthetic oil resistant rubber

Reinforcement: 1 high tensile steel wire braid

Cover: Synthetic rubber - abrasion, ozone & weather resistant

MSHA Approved

Temp. Range: -40°C to +120°C or (-40°F to +250°F)

Impulse Cycles: 150,000

PART NUMBER	Hose I.D.		Hose O.D.		Working Pressure		Burst Pressure		Min Bend Radius		Coupling Recommendations	
	inch	mm	inch	mm	psi	bar	psi	bar	inch	mm	crimp	reusable
	4MXI	1/4"	6.4	0.53	13.4	3,265	225	13,060	900	3.9	99	NH / TC
5MXI	5/16"	7.9	0.59	15.0	3,120	215	12,480	860	4.5	114	NH / TC	-
6MXI	3/8"	9.5	0.68	17.4	2,610	180	10,440	720	5.1	130	NH/TC/BW	R1
8MXI	1/2"	12.7	0.80	20.3	2,320	160	9,280	640	7.1	180	NH/TC/BW	R1
10MXI	5/8"	15.9	0.93	23.7	1,890	130	7,560	521	7.9	201	NH/TC/BW	-
12MXI	3/4"	19.0	1.09	27.7	1,525	105	6,100	421	9.5	241	NH/TC/BW	R1
16MXI	1"	25.4	1.40	35.6	1,275	88	5,100	352	11.8	300	NH/TC/BW	R1
20MXI	1-1/4"	31.8	1.69	43.0	915	63	3,660	252	16.5	419	NH / BW	-
24MXI	1-1/2"	38.1	1.98	50.4	725	50	2,900	200	19.7	500	BW	-
32MXI	2"	50.8	2.50	63.5	580	40	2,320	160	24.8	630	BW	-
40MXI	2-1/2"	63.5	3.13	79.5	362	25	1,450	100	30.0	762	-	-

BXI SERIES

SAE 100R2AT / EN 853 2SN

Meets or Exceeds requirements of SAE 100R2AT



Application: High pressure hydraulic oils, air & water

Construction

Tube: Synthetic oil resistant rubber

Reinforcement: 2 high tensile steel wire braid

Cover: Synthetic rubber - abrasion, ozone & weather resistant

MSHA Approved

Temp. Range: -40°C to +120°C or (-40°F to +250°F)

Impulse Cycles: 200,000

PART NUMBER	Hose I.D.		Hose O.D.		Working Pressure		Burst Pressure		Min Bend Radius		Coupling Recommendations	
	inch	mm	inch	mm	psi	bar	psi	bar	inch	mm	crimp	reusable
	4BXI	1/4"	6.4	0.59	15.1	5,800	400	23,200	1,600	4.0	102	NH / TC
5BXI	5/16"	7.9	0.66	16.7	5,100	352	20,400	1,407	4.5	114	NH / TC	-
6BXI	3/8"	9.5	0.75	19.1	4,800	331	19,200	1,324	5.1	130	NH/TC/BW	R2
8BXI	1/2"	12.7	0.87	22.2	4,000	276	16,000	1,103	7.1	180	NH/TC/BW	R2
10BXI	5/8"	15.9	1.00	25.4	3,600	248	14,400	993	7.9	201	NH/TC/BW	-
12BXI	3/4"	19.0	1.16	29.4	3,100	214	12,400	855	9.4	239	NH/TC/BW	R2
16BXI	1"	25.4	1.47	37.3	2,400	165	9,600	662	11.8	300	NH/TC/BW	R2
20BXI	1-1/4"	31.8	1.90	48.3	1,800	124	7,200	496	16.5	419	NH / BW	-
24BXI	1-1/2"	38.1	2.15	54.7	1,300	90	5,200	359	19.7	500	BW	-
32BXI	2"	50.8	2.65	67.4	1,160	80	4,640	320	24.8	630	BW	-
40BXI	2-1/2"	63.5	3.25	82.5	1,000	69	4,000	276	30.0	762	-	-

NATIONAL HOSE

WIRE BRAIDED HYDRAULIC HOSES

AMI SERIES

SAE 100R17

Meets or Exceeds requirements of SAE 100R17



1/4" & 3/8"



1/2" to 1"

Application: High pressure hydraulic oils
Construction

Tube: Synthetic oil resistant rubber

Reinforcement: 1 or 2 high tensile steel wire braid

Cover: Synthetic rubber - abrasion, ozone & weather resistant
MSHA Approved

Temp. Range: -40°C to +100°C or (-40°F to +212°F)

Impulse Cycles: Minimum 200,000

PART NUMBER	Hose I.D.		Hose O.D.		Working Pressure		Burst Pressure		Min Bend Radius		Recommendations	
	inch	mm	inch	mm	psi	bar	psi	bar	inch	mm	crimp	reusable
4AMI	1/4"	6.4	0.48	12.2	3,045	210	12,180	840	2.0	51	NH / TC	-
6AMI	3/8"	9.5	0.62	15.8	3,045	210	12,180	840	2.6	65	NH/TC/BW	-
8AMI	1/2"	12.7	0.79	20.1	3,045	210	12,180	840	3.5	90	NH/TC/BW	-
12AMI	3/4"	19.0	1.09	27.7	3,045	210	12,180	840	4.9	124	NH/TC/BW	-
16AMI	1"	25.4	1.48	37.6	3,045	210	12,180	840	5.9	150	NH/TC/BW	-

1/4" & 3/8" have 1-wire braid & 1/2" to 1" have 2-wire braids (Smaller Outside Diameters And Tighter Bend Radius Than SAE 100R1AT & 100R2AT Hoses)

FXI SERIES

SAE 100R16

Meets or Exceeds requirements of SAE 100R16



Application: High pressure hydraulic oils
Construction

Tube: Synthetic oil resistant rubber

Reinforcement: 1 or 2 high tensile steel wire braid

Cover: Synthetic rubber - abrasion, ozone & weather resistant
MSHA Approved

Temp. Range: -40°C to +100°C or (-40°F to +212°F)

Impulse Cycles: Minimum 200,000

PART NUMBER	Hose I.D.		Hose O.D.		Working Pressure		Burst Pressure		Min Bend Radius		Recommendations	
	inch	mm	inch	mm	psi	bar	psi	bar	inch	mm	crimp	reusable
4FXI	1/4"	6.4	0.54	13.7	5,000	345	20,000	1,379	2.0	51	NH / TC	-
6FXI	3/8"	9.5	0.69	17.5	4,000	276	16,000	1,103	2.5	64	NH/TC/BW	-
8FXI	1/2"	12.7	0.81	20.6	3,500	241	14,000	965	3.5	89	NH/TC/BW	-
12FXI	3/4"	19.0	1.10	27.9	2,250	155	9,000	621	4.8	122	NH/TC/BW	-
16FXI	1"	25.4	1.36	34.6	2,000	138	8,000	552	6.0	152	NH/TC/BW	-

Same Dimensions as 100R1AT or 1SN But Smaller Bend Radius-Higher Performance and lighter Than 100R2AT & Great Compactness and Flexibility

NATIONAL HOSE

WIRE BRAIDED HYDRAULIC HOSES

PFI SERIES POWERFLEX

Very High Pressure Exceeding EN 853 2SN



Application: Rigorous and demanding critical applications

Construction

Tube: Synthetic oil resistant rubber

Reinforcement: 2 Special high tensile steel wire braid

Cover: Synthetic rubber - abrasion, ozone & weather resistant
MSHA Approved

Temp. Range: -40°C to +120°C or (-40°F to +250°F)

Impulse Cycles: Minimum 200,000

PART NUMBER	Hose I.D.		Hose O.D.		Working Pressure		Burst Pressure		Min Bend Radius		Coupling Recommendations	
	inch	mm	inch	mm	psi	bar	psi	bar	inch	mm	crimp	reusable
4PFI	1/4"	6.4	0.52	13.2	5,800	400	23,200	1,600	2.0	51	NH / TC	-
5PFI	5/16"	7.9	0.61	15.4	5,100	352	20,400	1,407	2.2	55	NH / TC	-
6PFI	3/8"	9.5	0.68	17.4	4,800	331	19,200	1,324	2.5	62	TC / BW	-
8PFI	1/2"	12.7	0.78	19.9	4,000	276	16,000	1,103	3.6	90	TC / BW	-
10PFI	5/8"	15.9	0.92	23.5	4,000	276	16,000	1,103	4.0	102	TC / BW	-
12PFI	3/4"	19.0	1.18	30.1	4,000	276	16,000	1,103	6.0	152	TC / BW	-
16PFI	1"	25.4	1.50	38.2	3,600	248	14,400	993	8.0	203	TC / BW	-

Very High Pressure Exceeding EN 853 2SN Extra High Flexibility With Half SAE/DIN Bend Radius Compact O.D. For Better Routing In Tight Areas

JL SERIES SUPERJACK

For safety reasons we recommend tested assemblies



Application: Hydraulic jack applications used in jacking systems

Construction

Tube: Synthetic oil resistant rubber

Reinforcement: 2 high tensile steel wire braid

Cover: Synthetic rubber - abrasion, ozone & weather resistant
MSHA Approved

Temp. Range: -40°C to +50°C or (-40°F to +122°F)

10,000 psi Jacking Hose For (Static Pressure) Only

PART NUMBER	Hose I.D.		Hose O.D.		Working Pressure		Burst Pressure		Min Bend Radius		Coupling Recommendations	
	inch	mm	inch	mm	psi	bar	psi	bar	inch	mm	crimp	reusable
JL04	1/4"	6.4	0.58	14.8	10,000	690	20,000	1380	4.0	102	NH	-
JL06	3/8"	9.5	0.74	18.8	10,000	690	20,000	1380	5.0	127	NH	-

Recommended For Static (NON-IMPULSE) Applications - Pressure Ratings Are For Hydraulic Jacking Applications Only
1/4" & 3/8" Are Available In Standard Pre-made & Tested Assemblies Please Ask For A List Of Assemblies.

NATIONAL HOSE

WIRE BRAIDED HYDRAULIC HOSES

PW SERIES PRESSURE WASH

Standard 3,000 psi - Not for steam service



Application: Used on pressure washers for wash down service - Not for steam service

Construction

Tube: Synthetic oil resistant rubber

Reinforcement: 1 high tensile steel wire braid

Cover: Synthetic rubber - abrasion, ozone & weather resistant

Temp. Range: -40°C to +120°C or (-40°F to +250°F)

Impulse Cycles: 150,000

PART NUMBER	Hose I.D.		Hose O.D.		Working Pressure		Burst Pressure		Min Bend Radius		Coupling Recommendations	
	inch	mm	inch	mm	psi	bar	psi	bar	inch	mm	crimp	reusable
PW-04	1/4"	6.4	0.53	13.4	3,000	207	12,000	828	3.9	99	NH / TC	-
PW-06	3/8"	9.5	0.63	16.0	3,000	207	12,000	828	2.5	64	NH / TC	-

PW-NM / 4657 SERIES PRESSURE WASH

Standard 3,000 psi (Non-Marking) Cover



Application: Used on pressure washers for wash down service & In the Carpet Cleaning Ind. - Not for steam service

Construction

Tube: Synthetic oil resistant rubber

Reinforcement: 1 high tensile steel wire braid

Cover: Non-Marking Synthetic rubber - abrasion, ozone & weather resistant

Temp. Range: -40°C to +120°C or (-40°F to +250°F)

PART NUMBER	Hose I.D.		Hose O.D.		Working Pressure		Burst Pressure		Min Bend Radius		Coupling Recommendations	
	inch	mm	inch	mm	psi	bar	psi	bar	inch	mm	crimp	reusable
PW-04NM	1/4"	6.4	0.53	13.4	3,000	207	12,000	828	4.0	102	NH / TC	-
PW-06NM	3/8"	9.5	0.68	17.4	3,000	207	12,000	828	5.0	127	NH / TC	-

PW HP SERIES PRESSURE WASH

Extra High Pressure - Not for steam service



Application: Used on pressure washers for wash down service - Not for steam service

Construction

Tube: Synthetic oil resistant rubber

Reinforcement: 2 high tensile steel wire braid

Cover: Synthetic rubber - abrasion, ozone & weather resistant

Temp. Range: -40°C to +120°C or (-40°F to +250°F)

Impulse Cycles: 200,000

PART NUMBER	Hose I.D.		Hose O.D.		Working Pressure		Burst Pressure		Min Bend Radius		Coupling Recommendations	
	inch	mm	inch	mm	psi	bar	psi	bar	inch	mm	crimp	reusable
PW-04HP	1/4"	6.4	0.52	13.2	5,800	400	23,200	1,600	2.0	51	NH / TC	-
PW-06HP	3/8"	9.5	0.68	17.4	4,800	331	19,200	1,324	2.5	64	NH / TC	-

NATIONAL HOSE

TEXTILE BRAIDED HYDRAULIC HOSES

R4 SERIES

SAE100R4

Suction & Return line hose

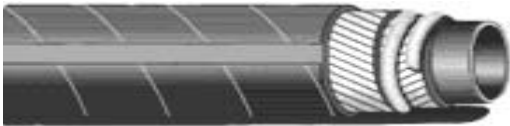

Application: Used for suction or return lines on hydraulic systems very flexible

Construction

Tube: Nitrile rubber

Reinforcement: Textile braids & steel wire helix

Cover: Synthetic rubber- abrasion, ozone & weather resistant

Temp. Range: -40°C to +120°C or (-40°F to +250°F)

Vacuum: 29 inch Hg

PART NUMBER	Hose I.D.		Hose O.D.		Working Pressure		Burst Pressure		Min Bend Radius		Coupling Recommendations	
	inch	mm	inch	mm	psi	bar	psi	bar	inch	mm	crimp	reusable
	R412	3/4"	19.0	1.20	30	300	21	1,200	83	2.0	51	NH/TC/BW
R416	1"	25.4	1.40	36	250	17	1,000	69	2.5	64	NH/TC/BW	
R420	1-1/4"	31.8	1.70	43	200	14	800	55	3.0	76	NH/TC/BW	
R424	1-1/2"	38.1	1.90	48	150	10	600	41	4.0	102	TC / BW	
R432	2"	50.8	2.50	64	100	7	400	28	6.0	152	TC / BW	
R440	2-1/2"	63.5	3.00	76	100	7	400	28	6.0	152		
R448	3"	76.2	3.50	89	100	7	400	28	8.0	203		

AU-05 SERIES

FLEX-LOC - Push On Hose

300 PSI Push on hose (Non-Conductive)



Application: For low pressures of oil, gasoline, air, water, coolant, robotic welders, etc

Construction

Tube: class A rubber (**Non-Conductive**)

Reinforcement: Special aramid Spiral

Cover: class A - abrasion, ozone & weather resistant & MSHA Approved

Temp. Range: -40°C to +100°C or (-40°F to +212°F)

PART NUMBER	Hose I.D.		Hose O.D.		Working Pressure		Burst Pressure		Min Bend Radius		Coupling Recommendations	
	inch	mm	inch	mm	psi	bar	psi	bar	inch	mm	crimp	reusable
	AU-05-004	1/4"	6.4	0.50	13	300	21	1,200	83	3.0	76	NH
AU-05-006	3/8"	9.5	0.62	16	300	21	1,200	83	3.0	76	NH	D360
AU-05-008	1/2"	12.7	0.75	19	300	21	1,200	83	5.0	127	NH	D360
AU-05-010	5/8"	15.9	0.91	23	300	21	1,200	83	6.0	152	NH	D360
AU-05-012	3/4"	19.0	1.44	37	300	21	1,200	83	8.0	203	NH	D360

Flex-Loc is Stocked in Black, Also Available in Grey & Blue -Do Not Exceede 300 psi Working Pressure When Using D360 Series Push-On Hose Barbs.

NATIONAL HOSE

WIRE BRAIDED & TEXTILE HYDRAULIC HOSE

R5 SERIES

SAE100R5 Cotton Cover

SAE J1402 Type All & DOT FMVSS-106

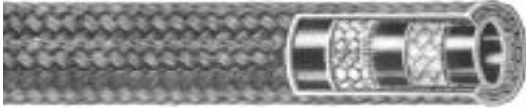

Application: For high temperature & medium pressure hydraulic lines on material handling equipment also for air, water or oil service.

Construction

Tube: Oil resistant synthetic rubber

Reinforcement: Textile inner braid & a steel wire braid

Cover: Oil and mildew resistant black textile braid

Temp. Range: -40°C to +100°C or (-40°F to +212°F)
(Intermittent to +300°F)

PART NUMBER	Hose I.D.		Hose O.D.		Working Pressure		Burst Pressure		Min Bend Radius		Coupling Recommendations	
	inch	mm	inch	mm	psi	bar	psi	bar	inch	mm	crimp	reusable
	R504	3/16"	4.8	0.52	13.2	3,000	207	12,000	827	3.0	76	NH
R505	1/4"	6.4	0.58	14.7	3,000	207	12,000	827	3.4	86	NH	R5
R506	5/16"	7.9	0.68	17.3	2,250	155	9,000	621	4.0	102	NH	R5
R508	13/32"	10.3	0.77	19.6	2,000	138	8,000	552	4.6	117	NH	R5
R510	1/2"	12.7	0.92	23.4	1,750	121	7,000	483	5.5	140	NH	R5
R512	5/8"	15.9	1.08	27.4	1,500	103	6,000	414	6.5	165	NH	R5
R516	7/8"	22.2	1.23	31.2	800	55	3,000	207	7.4	188	NH	R5
R520	1-1/8"	28.6	1.50	38.1	625	43	2,500	172	9.0	229	NH	R5
R524	1-3/8"	34.9	1.75	44.5	500	34	2,000	138	10.5	267	-	R5
R532	1-13/16"	46.0	2.22	56.4	350	24	1,400	97	13.3	338	-	R5

Note: Continuous use at maximum temperature & maximum working pressure will affect service life of this hose

BH SERIES

Barrier Refrigerant Hose

Exceeds SAE J51 & Meets SAE J2064



Application: Specifically designed for use in R12 & R134A refrigerant systems only.

Construction

Tube: Neoprene / nylon barrier / nitrile barrier

Reinforcement: Textile braid

Cover: Black abrasion, ozone & heat resistant EPDM rubber

Temp. Range: -22°F to +257°F

PART NUMBER	Hose I.D.		Hose O.D.		Working Pressure		Burst Pressure		Min Bend Radius		Coupling Recommendations	
	inch	mm	inch	mm	psi	bar	psi	bar	inch	mm	crimp	reusable
	BH06	5/16"	7.9	0.75	19.1	350	24	2,000	138	4.0	102	BL
BH08	13/32"	10.3	0.91	23.1	350	24	2,000	138	4.7	119	BL	-
BH10	1/2"	12.7	1.00	25.4	350	24	2,000	138	5.5	140	BL	-
BH12	5/8"	15.9	1.13	28.7	350	24	2,000	138	6.5	165	BL	-

NATIONAL HOSE

THERMOPLASTIC HYDRAULIC HOSES

R7 SERIES SAE100R7

Meets or Exceeds requirements of SAE 100R7



Application: Used for medium pressure hydraulic applications & agricultural equipment etc.

Construction

Tube: black, polyester

Reinforcement: Two braids of polyester fiber

Cover: Black Polyurethane-oil & abrasion resistant

Temp. Range: -40°C to +93°C or (-40°F to +200°F)

PART NUMBER	Hose I.D.		Hose O.D.		Working Pressure		Burst Pressure		Min Bend Radius		Coupling Recommendations	
	inch	mm	inch	mm	psi	bar	psi	bar	inch	mm	crimp	reusable
	R702	1/8"	3.2	0.32	8.1	3,400	234	13,500	931	0.5	13	NH
R703	3/16"	4.8	0.36	9.1	3,100	214	12,500	862	0.7	18	NH	
R704	1/4"	6.4	0.50	12.7	3,000	207	12,000	828	0.8	20	NH	
R705	5/16"	7.9	0.56	14.2	2,800	193	11,300	779	1.4	35	NH	
R706	3/8"	9.5	0.65	16.5	2,750	190	11,000	759	2.2	55	NH	
R708	1/2"	12.7	0.80	20.3	2,450	169	10,000	690	3.0	75	NH	
R712	3/4"	19.0	1.08	27.4	1,500	103	6,000	414	5.3	135	NH	
R716	1"	25.4	1.34	34.0	1,350	93	5,500	379	6.3	160	NH	

R7-NC SERIES

SAE100R7 - Non Conductive

Meets or Exceeds requirements of SAE 100R7



Application: Used for medium pressure hydraulic applications where a Non-Conductive hose is required

Construction

Tube: Natural, polyester

Reinforcement: Two braids of polyester fiber

Cover: Orange Polyurethane-oil & abrasion resistant

Temp. Range: -40°C to +93°C or (-40°F to +200°F)

PART NUMBER	Hose I.D.		Hose O.D.		Working Pressure		Burst Pressure		Min Bend Radius		Coupling Recommendations	
	inch	mm	inch	mm	psi	bar	psi	bar	inch	mm	crimp	reusable
	R702-NC	1/8"	3.2	0.32	8.1	3,400	234	13,500	931	0.5	13	NH
R703-NC	3/16"	4.8	0.36	9.1	3,100	214	12,500	862	0.7	18	NH	
R704-NC	1/4"	6.4	0.50	12.7	3,000	207	12,000	828	0.8	20	NH	
R705-NC	5/16"	7.9	0.56	14.2	2,800	193	11,300	779	1.4	35	NH	
R706-NC	3/8"	9.5	0.65	16.5	2,750	190	11,000	759	2.2	55	NH	
R708-NC	1/2"	12.7	0.80	20.3	2,450	169	10,000	690	3.0	75	NH	
R712-NC	3/4"	19.0	1.08	27.4	1,500	103	6,000	414	5.3	135	NH	
R716-NC	1"	25.4	1.34	34.0	1,350	93	5,500	379	6.3	160	NH	

NATIONAL HOSE

THERMOPLASTIC HYDRAULIC HOSES

R7TL SERIES

SAE100R7 - Twin Line

Meets or Exceeds requirements of SAE 100R7

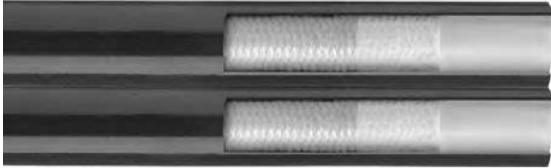

Application: Used for medium pressure hydraulic applications & agricultural equipment etc.







Construction

Tube: black, polyester

Reinforcement: Two braids of polyester fiber

Cover: Black Polyurethane-oil & abrasion resistant

Temp. Range: -40°C to +93°C or (-40°F to +200°F)

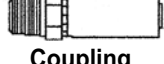
 PART NUMBER	 Hose I.D.		 Hose O.D.		 Working Pressure		 Burst Pressure		 Min Bend Radius		 Coupling	
	inch	mm	inch	mm	psi	bar	psi	bar	inch	mm	crimp	reusable
R704TL	1/4"	6.4	0.50	12.7	3,000	207	12,000	828	0.7	20	NH	
R705TL	5/16"	7.9	0.56	14.2	2,800	193	11,300	779	1.4	35	NH	
R706TL	3/8"	9.5	0.65	16.5	2,750	190	11,000	759	2.2	55	NH	
R708TL	1/2"	12.7	0.80	20.3	2,450	169	10,000	690	3.0	75	NH	

R7TL-NC SERIES

SAE100R7 - Non Conduvtive Twin Line

Meets or Exceeds requirements of SAE 100R7

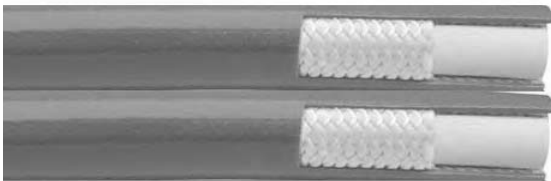

Application: Used for medium pressure hydraulic applications & agricultural equipment etc.







Construction

Tube: Natural, polyester

Reinforcement: Two braids of polyester fiber

Cover: Orange Polyurethane-oil & abrasion resistant

Temp. Range: -40°C to +93°C or (-40°F to +200°F)

 PART NUMBER	 Hose I.D.		 Hose O.D.		 Working Pressure		 Burst Pressure		 Min Bend Radius		 Coupling	
	inch	mm	inch	mm	psi	bar	psi	bar	inch	mm	crimp	reusable
R704TL-NC	1/4"	6.4	0.50	12.7	3,000	207	12,000	828	0.7	20	NH	
R705TL-NC	5/16"	7.9	0.56	14.2	2,800	193	11,300	779	1.4	35	NH	
R706TL-NC	3/8"	9.5	0.65	16.5	2,750	190	11,000	759	2.2	55	NH	
R708TL-NC	1/2"	12.7	0.80	20.3	2,450	169	10,000	690	3.0	75	NH	

NATIONAL HOSE

THERMOPLASTIC HYDRAULIC HOSES

R8 SERIES

SAE100R8

Meets or Exceeds requirements of SAE 100R8

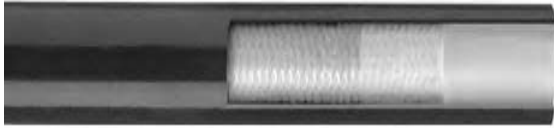

Application: Used for high pressure hydraulic applications & agricultural equipment etc.

Construction

Tube: black, polyester

Reinforcement: Two braids of polyester fiber

Cover: Black Polyurethane-oil & abrasion resisant

Temp. Range: -40°C to +93°C or (-40°F to +200°F)

PART NUMBER	Hose I.D.		Hose O.D.		Working Pressure		Burst Pressure		Min Bend Radius		Coupling Recommendations	
	inch	mm	inch	mm	psi	bar	psi	bar	inch	mm	crimp	reusable
	R802	1/8"	3.2	0.32	8.1	7,100	490	28,400	1,959	0.6	15	NH
R803	3/16"	4.8	0.36	9.1	5,850	403	23,450	1,617	0.9	22	NH	
R804	1/4"	6.4	0.50	12.7	5,850	403	23,450	1,617	1.2	30	NH	
R805	5/16"	7.9	0.56	14.2	5,685	392	22,800	1,572	1.6	40	NH	
R806	3/8"	9.5	0.65	16.5	5,550	383	22,000	1,517	2.8	70	NH	
R808	1/2"	12.7	0.80	20.3	3,550	245	14,200	979	3.5	90	NH	
R812	3/4"	19.0	1.08	27.4	2,450	169	9,700	669	5.9	150	NH	
R816	1"	25.4	1.34	34.0	2,150	148	8,500	586	7.5	190	NH	

R8-NC SERIES

SAE100R8 - Non Conductive

Meets or Exceeds requirements of SAE 100R8



Application: Used for high pressure hydraulic applications & agricultural equipment etc.

Construction

Tube: Natural, polyester

Reinforcement: Two braids of polyester fiber

Cover: Orange Polyurethane-oil & abrasion resisant

Temp. Range: -40°C to +93°C or (-40°F to +200°F)

PART NUMBER	Hose I.D.		Hose O.D.		Working Pressure		Burst Pressure		Min Bend Radius		Coupling Recommendations	
	inch	mm	inch	mm	psi	bar	psi	bar	inch	mm	crimp	reusable
	R802-NC	1/8"	3.2	0.32	8.1	7,100	490	28,400	1,959	0.6	15	NH
R803-NC	3/16"	4.8	0.36	9.1	5,850	403	23,450	1,617	0.9	22	NH	
R804-NC	1/4"	6.4	0.50	12.7	5,850	403	23,450	1,617	1.2	30	NH	
R805-NC	5/16"	7.9	0.56	14.2	5,685	392	22,800	1,572	1.6	40	NH	
R806-NC	3/8"	9.5	0.65	16.5	5,550	383	22,000	1,517	2.8	70	NH	
R808-NC	1/2"	12.7	0.80	20.3	3,550	245	14,200	979	3.5	90	NH	
R812-NC	3/4"	19.0	1.08	27.4	2,450	169	9,700	669	5.9	150	NH	
R816-NC	1"	25.4	1.34	34.0	2,150	148	8,500	586	7.5	190	NH	

NATIONAL HOSE

STAINLESS STEEL BRAIDED TEFLON HOSE

T1 SERIES

SMOOTHFLEX - Nominal Bore

Meets or Exceeds requirements of SAE 100R14A



Application: For use with corrosive and or high temperature fluids & steam

Construction

Tube: White PTFE Smooth bore meets FDA-3A requirements

Reinforcement & Cover: 1 braid of high tensile 304-Stainless steel wire

Temp. Range: -54°C to +232°C or (-65°F to +450°F)

PART NUMBER	Hose I.D.		Hose O.D.		Working Pressure		Burst Pressure		Min Bend Radius		Coupling Recommendations	
	inch	mm	inch	mm	psi	bar	psi	bar	inch	mm	crimp	reusable
T103	1/8"	3.2	.234	5.9	3,000	207	12,000	827	2.0	51	BR / ST	-
T104	3/16"	4.0	.312	7.9	3,000	207	12,000	827	2.0	51	DR / ST	-
T105	1/4"	6.4	.375	9.5	3,000	207	12,000	827	3.0	76	BR / ST	-
T106	5/16"	7.9	.445	11.3	2,500	172	10,000	690	4.0	102	BR / ST	-
T108	13/32"	10.3	.549	13.9	2,000	138	8,000	552	5.1	130	BR / ST	-
T110	1/2"	12.7	.648	16.5	1,500	103	6,000	414	6.6	168	BR / ST	-
T112	5/8"	15.9	.778	19.8	1,200	83	4,800	331	7.7	196	BR / ST	-
T116	7/8"	22.2	1.030	26.2	1,000	69	4,000	276	9.0	229	BR / ST	-

SmoothFlex Is Also Available With An Optional Black Conductive Liner For Electrostatic Dissipation - Also Available In Higher Working Pressures

PFSS SERIES

PROFLEX-Convuluted Hose

Stainless steel braided Convuluted Teflon hose



Application: For use with corrosive and or high temperature fluids & steam

Construction

Tube: White Pureflon convoluted meets FDA-3A requirements

Reinforcement & Cover: 1 braid of high tensile 304-Stainless steel wire

Temp. Range: -54°C to +232°C or (-65°F to +450°F)

PART NUMBER	Hose I.D.		Hose O.D.		Working Pressure		Burst Pressure		Min Bend Radius		Coupling Recommendations	
	inch	mm	inch	mm	psi	bar	psi	bar	inch	mm	crimp	reusable
PFSS-008	1/2"	12.7	.720	10.3	1,500	103	6,000	414	1.5	30	PF	-
PFSS-012	3/4"	19.0	1.035	26.3	1,100	76	4,400	303	2.0	51	PF	-
PFSS-016	1"	25.4	1.360	34.5	1,000	69	4,000	276	2.5	64	PF	-
PFSS-020	1-1/4"	31.8	1.600	40.6	825	57	3,300	228	3.5	89	PF	-
PFSS-024	1-1/2"	38.1	1.900	48.3	750	52	3,000	207	3.8	97	PF	-
PFSS-032	2"	50.8	2.370	60.2	625	43	2,500	172	6.5	165	PF	-

ProFlex Is Also Available With An Optional Black Conductive Liner For Electrostatic Dissipation - Also Available With A PolyPro Reinforcement

NATIONAL HOSE

AIRLESS WIRELESS PAINT SPRAY HOSE & ASSEMBLIES

HPS SERIES PAINT SPRAY HOSE

For safety reasons we recommend tested assemblies



Application: High pressure conductive hose suitable for conveying paints, oils and most solvents

Construction

Tube: Seamless Nylon

Reinforcement: High tensile synthetic fiber

Cover: Abrasion resistant Polyurethane (non-pin pricked)

Temp. Range: -40°C to +82°C or (-40°F to +180°F)

PART NUMBER	Hose I.D.		Hose O.D.		Working Pressure		Burst Pressure		Min Bend Radius		Coupling Recommendations	
	inch	mm	inch	mm	psi	bar	psi	bar	inch	mm	crimp	reusable
	HPS03	3/16"	4.8	0.43	11	3,300	228	13,200	910	2.0	51	NH
HPS04	1/4"	6.4	0.49	12	3,300	228	13,200	910	3.0	76	NH	
HPS06	3/8"	9.5	0.66	17	3,300	228	13,200	910	3.5	89	NH	

XHPS SERIES PAINT SPRAY ASSEMBLIES

Pre-made & tested hose assemblies



All Sizes Of Paint Spray Hose Assemblies Are Available In Custom Made To Order Lengths On Request.

PART NUMBER	Hose I.D.		Hose O.D.		Working Pressure		Burst Pressure		Min Bend Radius		Standard Assemblies	
	inch	mm	inch	mm	psi	bar	psi	bar	inch	mm	Length	Fitting E/E
	XHPS03-03C404	3/16"	4.8	0.43	11	3,300	228	13,200	910	2.0	51	25'
XHPS03-03G404	3/16"	4.8	0.43	11	3,300	228	13,200	910	2.0	51	50'	1/4" Npsm
XHPS03-03J404	3/16"	4.8	0.43	11	3,300	228	13,200	910	2.0	51	100'	1/4" Npsm
XHPS04-04C404	1/4"	6.4	0.49	12	3,300	228	13,200	910	3.0	76	25'	1/4" Npsm
XHPS04-04G404	1/4"	6.4	0.49	12	3,300	228	13,200	910	3.0	76	50'	1/4" Npsm
XHPS04-04J404	1/4"	6.4	0.49	12	3,300	228	13,200	910	3.0	76	100'	1/4" Npsm
XHPS06-06C606	3/8"	9.5	0.66	17	3,300	228	13,200	910	3.5	89	25'	3/8" Npsm
XHPS06-06G606	3/8"	9.5	0.66	17	3,300	228	13,200	910	3.5	89	50'	3/8" Npsm
XHPS06-06J606	3/8"	9.5	0.66	17	3,300	228	13,200	910	3.5	89	100'	3/8" Npsm

NATIONAL HOSE

WATERBLAST HOSE & ASSEMBLIES

WB SERIES

H.P. WATERBLAST HOSE

For safety reasons we recommend tested assemblies

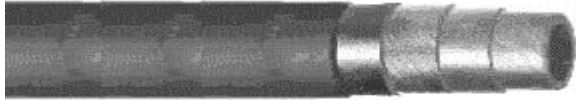

Application: Ultra high water blasting applications only.

Construction

Tube: Synthetic water resistant rubber

Reinforcement: 4 spiral high tencile steel wire

Cover: Synthetic rubber - abrasion ,ozone & weather resistant

Temp. Range: -10°C to +50°C or (-14°F to +122°F)

NOT RECOMMEND FOR HYDRAULIC APPLICATIONS

2.5:1 safety factor

PART NUMBER	Hose I.D.		Hose O.D.		Working Pressure		Burst Pressure		Min Bend Radius		Coupling Recommendations	
	inch	mm	inch	mm	psi	bar	psi	bar	inch	mm	crimp	reusable
	WB-01-006	3/8"	9.5	0.70	18	18,000	1,241	45,000	3,103	6.0	152	SPECIAL
WB-01-008	1/2"	12.7	0.89	23	16,000	1,103	40,000	2,758	8.0	203	SPECIAL	-
WB-01-012	3/4"	19.5	1.18	28	12,000	827	30,000	2,069	11.0	279	SPECIAL	-
WB-01-016	1"	25.4	1.39	35	10,000	690	25,000	1,724	14.0	356	SPECIAL	-

XWB SERIES

WATERBLAST ASSEMBLIES

Pre-made & tested hose assemblies

All Sizes Of WaterBlast Hose Assemblies Are Available In Custom Made To Order Lengths On Request.



PART NUMBER	Hose I.D.		Hose O.D.		Working Pressure		Burst Pressure		Min Bend Radius		Assemblies	
	inch	mm	inch	mm	psi	bar	psi	bar	inch	mm	Length	Fitting E/E
	XWB06-10MM	3/8"	9.5	0.70	18	18,000	1,241	45,000	3,103	6.0	152	10'
XWB06-25MM	3/8"	9.5	0.70	18	18,000	1,241	45,000	3,103	6.0	152	25'	3/8" Npt
XWB06-50MM	3/8"	9.5	0.70	18	18,000	1,241	45,000	3,103	6.0	152	50'	3/8" Npt
XWB08-25MM	1/2"	12.7	0.89	23	16,000	1,103	40,000	2,758	8.0	203	25'	1/2" Npt
XWB08-50MM	1/2"	12.7	0.89	23	16,000	1,103	40,000	2,758	8.0	203	50'	1/2" Npt
XWB12-25MM	3/4"	19.5	1.18	28	12,000	827	30,000	2,069	11.0	279	25'	3/4" Npt
XWB12-50MM	3/4"	19.5	1.18	28	12,000	827	30,000	2,069	11.0	279	50'	3/4" Npt
XWB16-25MM	1"	25.4	1.39	35	10,000	690	25,000	1,724	14.0	356	25'	1" Npt
XWB16-50MM	1"	25.4	1.39	35	10,000	690	25,000	1,724	14.0	356	50'	1" Npt

NATIONAL HOSE

SPIRAL WIRE HYDRAULIC HOSE

CEI SERIES

SAE 100R12 / EN 856 R12

Meets or Exceeds requirements of SAE 100R12

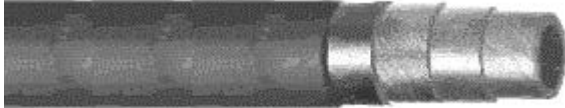

Application: Very high pressure hydraulic lines & mobile mining equipment

Construction

Tube: Synthetic oil resistant rubber

Reinforcement: 4 high tensile steel spiral wires

Cover: Synthetic rubber - abrasion, ozone & weather resistant
MSHA Approved

Temp. Range: -40°C to +100°C or (-40°F to +212°F) & +120°C or (+250°F) Intermittent

Impulse Cycles: 500,000

PART NUMBER	Hose I.D.		Hose O.D.		Working Pressure		Burst Pressure		Min Bend Radius		Coupling Recommendations	
	inch	mm	inch	mm	psi	bar	psi	bar	inch	mm	crimp	reusable
6CEI	3/8"	9.5	0.79	20.1	4,000	276	16,000	1,100	5.0	127	TC / BW	
8CEI	1/2"	12.7	0.93	23.6	4,000	276	16,000	1,100	7.0	178	TC / BW	
10CEI	5/8"	15.9	1.07	27.2	4,000	276	16,000	1,100	8.0	203	TC / BW	
12CEI	3/4"	19.0	1.20	30.5	4,000	276	16,000	1,100	9.5	241	TC / BW	
16CEI	1"	25.4	1.49	37.8	4,000	276	16,000	1,100	12.0	305	TC / BW	
20CEI	1-1/4"	31.8	1.84	46.8	3,000	207	12,000	825	16.5	419	BW / JJ	
24CEI	1-1/2"	38.1	2.10	53.3	2,500	172	10,000	685	20.0	508	BW / JJ	
32CEI	2"	50.8	2.62	66.5	2,500	172	10,000	685	25.0	635	BW / JJ	

4SP/4SH SERIES

EN 856 4SP / EN 856 4SH

Meets or Exceeds requirements of DIN 20023



Application: A superior spiral hose used in sever high pressure hydraulic applications

Construction

Tube: Synthetic oil resistant rubber

Reinforcement: 4 high tensile steel spiral wires

Cover: Synthetic rubber - abrasion, ozone & weather resistant
MSHA Approved

Temp. Range: -40°C to +100°C or (-40°F to +212°F) & +120°C or (+250°F) Intermittent

Impulse Cycles: 400,000

PART NUMBER	Hose I.D.		Hose O.D.		Working Pressure		Burst Pressure		Min Bend Radius		Coupling Recommendations	
	inch	mm	inch	mm	psi	bar	psi	bar	inch	mm	crimp	reusable
4SP06	3/8"	9.5	0.83	21.2	6,450	445	25,800	1,780	7.1	180	TC / BW	
4SP08	1/2"	12.7	0.96	24.4	6,020	415	24,070	1,660	9.0	230	TC / BW	
4SP10	5/8"	15.9	1.10	28.0	5,075	350	20,300	1,400	9.8	250	TC / BW	
4SH12	3/4"	19.0	1.26	32.0	6,100	420	24,360	1,680	11.0	280	TC / BW	
4SH16	1"	25.4	1.51	38.5	5,516	380	22,040	1,520	13.3	340	TC / BW	
4SH20	1-1/4"	31.8	1.78	45.3	4,720	325	18,850	1,300	18.1	460	BW / JJ	
4SH24	1-1/2"	38.1	2.10	53.3	4,210	290	16,820	1,160	22.0	560	BW / JJ	
4SH32	2"	50.8	2.67	67.9	3,625	250	14,500	1,000	27.5	700	BW / JJ	

NATIONAL HOSE

SPIRAL WIRE HYDRAULIC HOSE

NHI SERIES

SAE 100R13 / EN 856 R13

Meets or Exceeds requirements of SAE 100R13

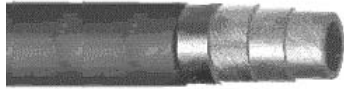

3/4" & 1"



1-1/4" to 2"

Application: A superior spiral hose used in sever high pressure hydraulic applications

Construction

Tube: Synthetic oil resistant rubber

Reinforcement: 4 or 6 high tensile steel spiral wires

Cover: Synthetic rubber - abrasion, ozone & weather resistant
MSHA Approved

Temp. Range: -40°C to +100°C or (-40°F to +212°F) & +120°C or (+250°F) Intermittent

Impulse Cycles: 500,000

PART NUMBER	Hose I.D.		Hose O.D.		Working Pressure		Burst Pressure		Min Bend Radius		Coupling Recommendations	
	inch	mm	inch	mm	psi	bar	psi	bar	inch	mm	crimp	reusable
	12NHI	3/4"	19.0	1.25	31.9	5,000	345	20,000	1,380	9.5	241	BW / JJ
16NHI	1"	25.4	1.51	38.5	5,000	345	20,000	1,380	12.0	305	BW / JJ	
20NHI	1-1/4"	31.8	1.95	49.6	5,000	345	20,000	1,380	16.5	419	JJ	
24NHI	1-1/2"	38.1	2.25	57.1	5,000	345	20,000	1,380	20.0	508	JJ	
32NHI	2"	50.8	2.79	70.9	5,000	345	20,000	1,380	25.0	635	JJ	

3/4" & 1" Have 4 Spirals Of Wire Reinforcement & 1-1/4" to 2" Have 6 Spirals Of Wire Reinforcement

N2I SERIES

SAE 100R15 / EN 856 R15

Meets or Exceeds requirements of SAE 100R15



3/4" & 1"



1-1/4" to 2"

Application: For extremely high pressure & heavy duty high impulse hydraulic applications

Construction

Tube: Synthetic oil resistant rubber

Reinforcement: 4 or 6 high tensile steel spiral wires

Cover: Synthetic rubber - abrasion, ozone & weather resistant
MSHA Approved

Temp. Range: -40°C to +100°C or (-40°F to +212°F) & +120°C or (+250°F) Intermittent

Impulse Cycles: 500,000



PART NUMBER	Hose I.D.		Hose O.D.		Working Pressure		Burst Pressure		Min Bend Radius		Coupling Recommendations	
	inch	mm	inch	mm	psi	bar	psi	bar	inch	mm	crimp	reusable
	12N2I	3/4"	19.0	1.26	32.0	6,000	414	24,000	1655	10.5	267	JJ
16N2I	1"	25.4	1.51	38.5	6,000	414	24,000	1655	13.0	330	JJ	
20N2I	1-1/4"	31.8	1.95	49.6	6,000	414	24,000	1655	17.5	445	JJ	
24N2I	1-1/2"	38.1	2.25	57.1	6,000	414	24,000	1655	21.0	533	JJ	



This Hose Exceeds Din 20023 4SH & Sae 100R13 spec. Particularly On Impulse Test & Burst Pressures

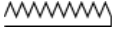

3/4" & 1" Have 4 Spirals Of Wire Reinforcement & 1-1/4" to 2" Have 6 Spirals Of Wire Reinforcement

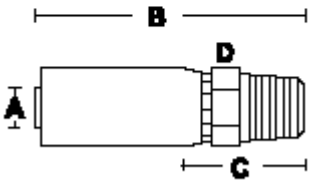
NATIONAL HOSE

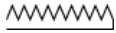
"NH" SERIES CRIMP COUPLINGS FOR BRAIDED HYDRAULIC HOSES

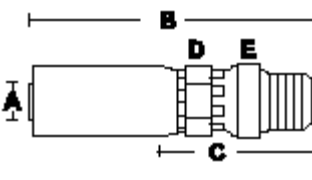

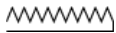

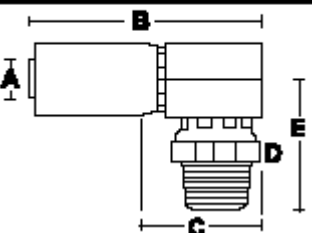
MALE PIPE NPTF RIGID	PART NUMBER			BARB A	O.A.L B	CUT OFF C			DROP F
		HOSE I.D.	THREAD				D	E	
	NH04-02MP	1/4"	1/8"-27	0.250	2.13	1.05	5/8"		
	NH04-04MP	1/4"	1/4"-18	0.250	2.31	1.25	11/16"		
	NH04-06MP	1/4"	3/8"-18	0.250	2.40	1.31	3/4"		
	NH04-08MP	1/4"	1/2"-14	0.250	2.63	1.38	15/16"		
	NH06-04MP	3/8"	1/4"-18	0.375	2.59	1.13	3/4"		
	NH06-06MP	3/8"	3/8"-18	0.375	2.59	1.13	3/4"		
	NH06-08MP	3/8"	1/2"-14	0.375	2.84	1.38	15/16"		
	NH08-06MP	1/2"	3/8"-18	0.500	2.78	1.13	3/4"		
	NH08-08MP	1/2"	1/2"-14	0.500		1.38	15/16"		
	NH08-12MP	1/2"	3/4"-14	0.500	3.62	1.38	1-1/8"		
	NH10-08MP	5/8"	1/2"-14	0.625	3.03	1.38	15/16"		
	NH10-12MP	5/8"	3/4"-14	0.625	3.22	1.38	1-1/8"		
	NH12-08MP	3/4"	1/2"-14	0.750	3.62	1.38	1"		
	NH12-12MP	3/4"	3/4"-14	0.750	3.22	1.38	1-1/8"		
	NH12-16MP	3/4"	1"-11 1/2	0.750	3.97	1.56	1-3/8"		
	NH16-12MP	1"	3/4"-14	1.000	3.45	1.38	1-1/8"		
	NH16-16MP	1"	1"-11 1/2	1.000	3.97	1.56	1-3/8"		
	NH20-20MP	1-1/4"	1-1/4"-11 1/2	1.250	4.60	2.31	1-11/16"		





MALE PIPE NPTF SWIVEL	PART NUMBER			BARB A	O.A.L B	CUT OFF C			DROP F
		HOSE I.D.	THREAD				D	E	
 <p>Swivels for installation</p>	NH04-02MPX	1/4"	1/8"-27	0.250	2.35	1.55	5/8"	11/16"	
	NH04-04MPX	1/4"	1/4"-18	0.250	2.87	1.81	5/8"	11/16"	
	NH04-06MPX	1/4"	1/4"-18	0.250	3.12	1.81	5/8"	3/4"	
	NH06-04MPX	3/8"	1/4"-18	0.375	3.15	1.81	5/8"	11/16"	
	NH06-06MPX	3/8"	3/8"-18	0.375	3.15	1.69	3/4"	3/4"	
	NH06-08MPX	3/8"	1/2"-14	0.375	3.34	1.94	3/4"	15/16"	
	NH08-06MPX	1/2"	3/8"-18	0.500	3.15	1.69	3/4"	3/4"	
	NH08-08MPX	1/2"	1/2"-14	0.500	3.61	1.94	15/16"	15/16"	
	NH12-12MPX	3/4"	3/4"-14	0.750	3.84	2.00	1-1/8"	1-1/8"	
	NH16-16MPX	1"	1"-11 1/2	1.000	4.65	2.33	1-3/8"	1-1/2"	

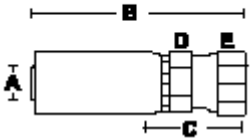

MALE PIPE SWIVEL 90	PART NUMBER			BARB A	O.A.L B	CUT OFF C		DROP E	
		HOSE I.D.	THREAD				D		F
 <p>Swivels for installation</p>	NH04-04MPX90	1/4"	1/4"-18	0.250	2.25	1.25	11/16"	1.70	
	NH04-06MPX90	1/4"	3/8"-18	0.250	2.43	1.25	3/4"	1.80	
	NH06-06MPX90	3/8"	3/8"-18	0.375	2.50	1.35	3/4"	1.80	
	NH06-08MPX90	3/8"	1/2"-14	0.375	2.50	1.35	15/16"	1.90	
	NH08-08MPX90	1/2"	1/2"-14	0.500	3.00	1.42	15/16"	1.90	
	NH12-12MPX90	3/4"	3/4"-14	0.750	3.25	1.25	1-3/4"	1.25	

NATIONAL HOSE

"NH" SERIES CRIMP COUPLINGS FOR BRAIDED HYDRAULIC HOSES

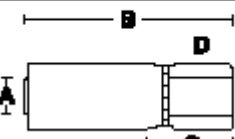
NPSM FEMALE PIPE SWIVEL	PART NUMBER			BARB A	O.A.L B	CUT OFF C			DROP F
		HOSE I.D.	THREAD				D	E	
	NH03-04FPX	3/16"	1/4"-18	0.187	2.28	1.44	5/8"	3/4"	
	NH04-04FPX	1/4"	1/4"-18	0.250	2.38	1.31	5/8"	3/4"	
	NH06-06FPX	3/8"	3/8"-18	0.375	2.66	1.19	3/4"	7/8"	
	NH08-08FPX	1/2"	1/2"-14	0.500	2.06	1.38	1"	1"	
	NH12-12FPX	3/4"	3/4"-14	0.750	3.84	2.00	1-1/8"	1-1/8"	
	NH16-16FPX	1"	1"-11 1/2	1.000	4.65	2.33	1-1/2"	1-1/2"	

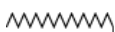
NPSM FEMALE PIPE RIGID	PART NUMBER			BARB A	O.A.L B	CUT OFF C			DROP F
		HOSE I.D.	THREAD				D	E	
	NH04-02FP	1/4"	1/8"-27	0.250	2.34	0.84	5/8"		
	NH04-04FP	1/4"	1/4"-18	0.250	2.34	0.84	3/4"		
	NH06-06FP	3/8"	3/8"-18	0.375	2.62	0.94	7/8"		
	NH08-08FP	1/2"	1/2"-14	0.500	3.03	1.09	1-1/16"		
	NH12-12FP	3/4"	3/4"-14	0.750	3.15	1.25	1-1/4"		
	NH16-16FP	1"	1"-11 1/2	1.000	3.27	1.66	1-1/2"		

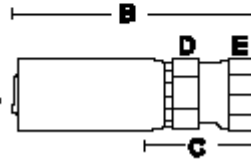
37 JIC FEMALE SWIVEL	PART NUMBER			BARB A	O.A.L B	CUT OFF C			DROP F
		HOSE I.D.	THREAD				D	E	
	NH02-03FJX	1/8"	3/8"-24	0.125	1.76	1.44	9/16"	1/2"	
	NH03-04FJX	3/16"	7/16"-20	0.187	2.24	1.44	5/8"	5/8"	
	NH03-05FJX	3/16"	1/2"-20	0.187	2.24	1.44	5/8"	3/4"	
	NH04-03FJX	1/4"	3/8"-24	0.250	2.53	1.44	5/8"	1/2"	
	NH04-04FJX	1/4"	7/16"-20	0.250	2.53	1.44	5/8"	5/8"	
	NH04-05FJX	1/4"	1/2"-20	0.250	2.53	1.44	5/8"	3/4"	
	NH04-06FJX	1/4"	9/16"-18	0.250	2.53	1.44	5/8"	3/4"	
	NH04-08FJX	1/4"	3/4"-16	0.250	2.67	1.44	5/8"	15/16"	
	NH06-05FJX	3/8"	1/2"-20	0.375	2.73	1.38	3/4"	3/4"	
	NH06-06FJX	3/8"	9/16"-18	0.375	2.81	1.38	3/4"	3/4"	
	NH06-08FJX	3/8"	3/4"-16	0.375	2.81	1.38	3/4"	15/16"	
	NH06-10FJX	3/8"	7/8"-14	0.375	2.94	1.50	7/8"	1-1/16"	
	NH08-06FJX	1/2"	9/16"-18	0.500	2.95	1.38	3/4"	3/4"	
	NH08-08FJX	1/2"	3/4"-16	0.500	3.16	1.50	7/8"	15/16"	
	NH08-10FJX	1/2"	7/8"-14	0.500	3.16	1.50	7/8"	1-1/16"	
	NH08-12FJX	1/2"	1-1/16"-12	0.500	3.24	1.63	1-1/8"	1-1/4"	
	NH10-08FJX	5/8"	3/4"-16	0.625	3.24	1.50	7/8"	15/16"	
	NH10-10FJX	5/8"	7/8"-14	0.625	3.35	1.50	7/8"	1-1/16"	
	NH10-12FJX	5/8"	1-1/16"-12	0.625	3.45	1.63	1-1/8"	1-1/4"	
	NH12-08FJX	3/4"	3/4"-16	0.750	3.44	1.63	1-1/8"	15/16"	
	NH12-12FJX	3/4"	1-1/16"-12	0.750	3.44	1.63	1-1/8"	1-1/4"	
	NH12-14FJX	3/4"	1-3/16"-12	0.750	0.44	1.63	1-1/8"	1-1/4"	
	NH12-16FJX	3/4"	1-5/16"-12	0.750	3.50	1.69	1-3/8"	1-1/2"	
	NH16-12FJX	1"	1-1/16"-12	1.000	3.62	1.63	1-1/8"	1-1/4"	
NH16-16FJX	1"	1-5/16"-12	1.000	4.06	1.69	1-3/8"	1-1/2"		
NH16-20FJX	1"	1-5/8"-12	1.000	4.90	2.50	1-11/16"	2"		
NH20-20FJX	1-1/4"	1-5/8"-12	1.250	4.90	2.50	1-11/16"	2"		

NATIONAL HOSE

"NH" SERIES CRIMP COUPLINGS FOR BRAIDED HYDRAULIC HOSES

**37 JIC FEMALE
45 TUBE SWIVEL**

Technical drawing of a 37 JIC Female 45 Tube Swivel. The drawing shows a side view of the swivel with dimensions labeled: A (tube length), B (overall length), C (cut-off length), D (barb diameter), E (drop length), and F (drop diameter). The swivel is shown in a 45-degree angle.

PART NUMBER	HOSE I.D.	THREAD	BARB A	O.A.L B	CUT OFF C	D	DROP E	F
NH04-04FJX45	1/4"	7/16"-20	0.250	2.57	1.47	5/8"	0.467	9/16"
NH04-05FJX45	1/4"	1/2"-20	0.250	2.57	1.47	5/8"	0.467	9/16"
NH04-06FJX45	1/4"	9/16"-18	0.250	2.92	1.50	5/8"	0.588	11/16"
NH06-04FJX45	3/8"	7/16"-20	0.375	2.57	1.47	5/8"	0.467	9/16"
NH06-06FJX45	3/8"	9/16"-18	0.375	2.92	1.50	3/4"	0.588	11/16"
NH06-08FJX45	3/8"	3/4"-16	0.375	3.28	1.63	3/4"	0.713	7/8"
NH08-06FJX45	1/2"	9/16"-18	0.500	2.92	1.50	3/4"	0.588	11/16"
NH08-08FJX45	1/2"	3/4"-16	0.500	3.28	1.63	7/8"	0.713	7/8"
NH08-10FJX45	1/2"	7/8"-14	0.500	3.52	1.84	1"	0.839	1"
NH10-10FJX45	5/8"	7/8"-14	0.625	3.52	1.84	1"	0.839	1"
NH10-12FJX45	5/8"	1-1/16"-12	0.625	4.33	2.44	1-1/8"	1.180	1-1/4"
NH12-12FJX45	3/4"	1-1/16"-12	0.750	4.33	2.44	1-1/8"	1.180	1-1/4"
NH12-16FJX45	3/4"	1-5/16"-12	0.750	4.88	2.88	1-1/2"	0.925	1-1/2"
NH16-16FJX45	1"	1-5/16"-12	1.000	4.88	2.88	1-1/2"	0.925	1-1/2"
NH20-20FJX45	1-1/4"	1-5/8"-12	1.250	5.23	3.41	2"	1.110	2"

**37 JIC FEMALE
90 TUBE SWIVEL**

Technical drawing of a 37 JIC Female 90 Tube Swivel. The drawing shows a side view of the swivel with dimensions labeled: A (tube length), B (overall length), C (cut-off length), D (barb diameter), E (drop length), and F (drop diameter). The swivel is shown in a 90-degree angle.

PART NUMBER	HOSE I.D.	THREAD	BARB A	O.A.L B	CUT OFF C	D	DROP E	F
NH04-04FJX90	1/4"	7/16"-20	0.250	2.28	1.31	5/8"	0.875	9/16"
NH04-05FJX90	1/4"	1/2"-20	0.250	2.28	1.31	5/8"	0.875	9/16"
NH04-06FJX90	1/4"	9/16"-18	0.250	2.44	1.19	5/8"	1.125	11/16"
NH06-04FJX90	3/8"	7/16"-20	0.375	2.28	1.31	5/8"	0.875	9/16"
NH06-06FJX90	3/8"	9/16"-18	0.375	2.63	1.19	3/4"	1.125	11/16"
NH06-08FJX90	3/8"	3/4"-16	0.375	2.75	1.31	3/4"	1.375	7/8"
NH08-06FJX90	1/2"	9/16"-18	0.500	2.63	1.19	3/4"	1.125	11/16"
NH08-08FJX90	1/2"	3/4"-16	0.500	2.94	1.31	7/8"	1.375	7/8"
NH08-10FJX90	1/2"	7/8"-14	0.500	3.06	1.44	1"	1.000	1"
NH10-10FJX90	5/8"	7/8"-14	0.625	3.06	1.44	1"	1.000	1"
NH10-12FJX90	5/8"	1-1/16"-12	0.625	3.88	2.06	1-1/8"	2.312	1-1/4"
NH12-12FJX90	3/4"	1-1/16"-12	0.750	3.88	2.06	1-1/8"	2.312	1-1/4"
NH12-16FJX90	3/4"	1-5/16"-12	0.750	4.75	2.31	1-1/2"	2.500	1-1/2"
NH16-16FJX90	1"	1-5/16"-12	1.000	4.75	2.31	1-1/2"	2.500	1-1/2"
NH20-20FJX90	1-1/4"	1-5/8"-12	1.250	5.58	3.75	2"	2.580	2"



**37 JIC FEMALE
90 TUBE SWIVEL LONG DROP**



Technical drawing of a 37 JIC Female 90 Tube Swivel Long Drop. The drawing shows a side view of the swivel with dimensions labeled: A (tube length), B (overall length), C (cut-off length), D (barb diameter), E (drop length), and F (drop diameter). The swivel is shown in a 90-degree angle with a longer drop than the standard version.



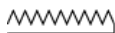

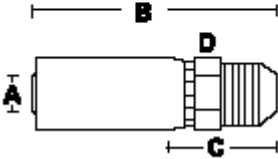
PART NUMBER	HOSE I.D.	THREAD	BARB A	O.A.L B	CUT OFF C	D	DROP E	F
NH04-04FJX90L	1/4"	7/16"-20	0.250	2.31	1.23	5/8"	1.80	9/16"
NH04-06FJX90L	1/4"	9/16"-18	0.250	2.74	1.43	3/4"	2.18	11/16"
NH06-04FJX90L	3/8"	7/16"-20	0.375	2.31	1.23	5/8"	1.80	9/16"
NH06-06FJX90L	3/8"	9/16"-18	0.375	2.74	1.43	3/4"	2.18	11/16"
NH06-08FJX90L	3/8"	3/4"-16	0.375	3.04	1.48	7/8"	2.43	7/8"
NH08-08FJX90L	1/2"	3/4"-16	0.500	3.04	1.48	7/8"	2.43	7/8"
NH08-10FJX90L	1/2"	7/8"-14	0.500	3.18	1.55	7/8"	2.65	1"
NH10-10FJX90L	5/8"	7/8"-14	0.625	3.18	1.55	7/8"	2.65	1"
NH12-12FJX90L	3/4"	1-1/16"-12	0.750	3.78	2.02	1-1/16"	3.73	1-1/4"
NH16-16FJX90L	1"	1-5/16"-12	1.000	4.88	2.88	1-1/2"	4.35	1-1/2"

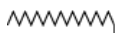
NATIONAL HOSE

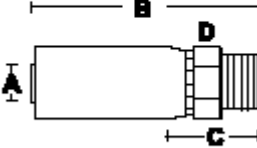
"NH" SERIES CRIMP COUPLINGS FOR BRAIDED HYDRAULIC HOSES

37 JIC MALE RIGID	PART NUMBER			BARB A	O.A.L B	CUT OFF C			DROP F
		HOSE I.D.	THREAD				D	E	
	NH04-04MJ	1/4"	7/16"-20	0.250	2.30	1.25	5/8"		
	NH04-05MJ	1/4"	1/2"-20	0.250	2.30	1.25	5/8"		
	NH04-06MJ	1/4"	9/16"-18	0.250	2.45	1.13	3/4"		
	NH06-06MJ	3/8"	9/16"-18	0.375	2.59	1.13	3/4"		
	NH06-08MJ	3/8"	3/4"-16	0.375	2.69	1.25	13/16"		
	NH06-10MJ	3/8"	7/8"-14	0.375	2.75	1.25	15/16"		
	NH08-08MJ	1/2"	3/4"-16	0.500	2.88	1.25	7/8"		
	NH08-10MJ	1/2"	7/8"-14	0.500	3.10	1.44	15/16"		
	NH08-12MJ	1/2"	1-1/16"-12	0.500	3.20	1.50	1-1/8"		
	NH10-10MJ	5/8"	7/8"-14	0.625	3.10	1.44	15/16"		
	NH10-12MJ	5/8"	1-1/16"-12	0.625	3.10	1.44	1-1/8"		
	NH12-12MJ	3/4"	1-1/16"-12	0.750	3.32	1.50	1-1/8"		
	NH12-14MJ	3/4"	1-3/16"-12	0.750	3.32	1.50	1-1/8"		
	NH12-16MJ	3/4"	1-5/16"-12	0.750	3.77	1.63	1-3/8"		
	NH16-16MJ	1"	1-5/16"-12	1.000	3.97	1.63	1-3/8"		
	NH20-20MJ	1-1/4"	1-5/8"-12	1.250	4.09	2.25	2"		

MALE BOSS O-RING RIGID	PART NUMBER			BARB A	O.A.L B	CUT OFF C			DROP F
		HOSE I.D.	THREAD				D	E	
	NH04-04MB	1/4"	7/16"-20	0.250	2.11	1.03	5/8"		
	NH04-05MB	1/4"	1/2"-20	0.250	2.11	1.03	5/8"		
	NH04-06MB	1/4"	9/16"-20	0.250	2.14	1.06	11/16"		
	NH04-08MB	1/4"	3/4"-16	0.250	2.63	1.09	15/16"		
	NH06-06MB	3/8"	9/16"-20	0.375	2.42	1.00	3/4"		
	NH06-08MB	3/8"	3/4"-16	0.375	2.47	1.03	7/8"		
	NH06-10MB	3/8"	7/8"-14	0.375	2.78	1.09	1-1/16"		
	NH08-08MB	1/2"	3/4"-16	0.500	2.78	1.09	15/16"		
	NH08-10MB	1/2"	7/8"-14	0.500	2.84	1.16	1-1/16"		
	NH10-10MB	5/8"	7/8"-14	0.625	2.93	1.16	1-1/16"		
	NH12-10MB	3/4"	7/8"-14	0.750	2.93	1.16	1-1/16"		
	NH12-12MB	3/4"	1-1/16"-12	0.750	3.06	1.25	1-1/4"		
	NH16-16MB	1"	1-5/16"-12	1.000	3.62	1.30	1-1/2"		

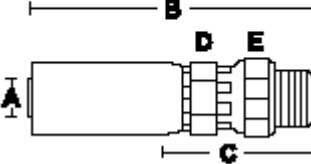
MALE BOSS O-RING SWIVEL	PART NUMBER			BARB A	O.A.L B	CUT OFF C			DROP F
		HOSE I.D.	THREAD				D	E	
 <p>Swivels for installation</p>	NH04-04MBX	1/4"	7/16"-20	0.250	2.87	1.81	5/8"	11/16"	
	NH04-06MBX	1/4"	9/16"-20	0.250	3.12	1.91	5/8"	3/4"	
	NH06-06MBX	3/8"	9/16"-20	0.375	3.15	1.69	3/4"	3/4"	
	NH06-08MBX	3/8"	3/4"-16	0.375	3.34	1.94	3/4"	15/16"	
	NH08-08MBX	1/2"	3/4"-16	0.500	3.60	1.94	15/16"	15/16"	
	NH08-10MBX	1/2"	7/8"-14	0.500	3.80	2.05	15/16"	1"	
NH12-12MBX	3/4"	1-1/16"-12	0.750	3.52	1.25	1-3/4"	1-1/4"		

NATIONAL HOSE

"NH" SERIES CRIMP COUPLINGS FOR BRAIDED HYDRAULIC HOSES

MALE BOSS O-RING SWIVEL 90

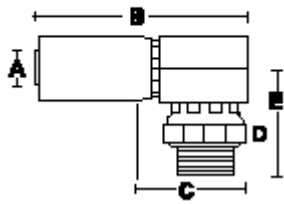

Swivels for installation

PART NUMBER	HOSE I.D.	THREAD	BARB A	O.A.L B	CUT OFF C	D	DROP E	F
NH04-04MBX90	1/4"	7/16"-20	0.250	2.25	1.25	11/16"	1.70	
NH04-06MBX90	1/4"	9/16"-20	0.250	2.43	1.25	3/4"	1.80	
NH06-06MBX90	3/8"	9/16"-20	0.375	2.50	1.35	3/4"	1.80	
NH06-08MBX90	3/8"	3/4"-16	0.375	2.50	1.35	15/16"	1.85	
NH08-08MBX90	1/2"	3/4"-16	0.500	3.00	1.42	15/16"	1.90	
NH08-10MBX90	1/2"	7/8"-14	0.500	3.00	1.42	15/16"	1.90	
NH12-12MBX90	3/4"	1-1/16"-12	0.750	3.25	1.25	1-3/4"	1.25	

O-RING FACE SEAL FEMALE SWIVEL

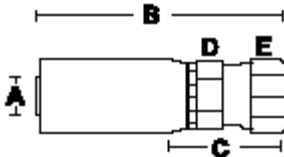

PART NUMBER	HOSE I.D.	THREAD	BARB A	O.A.L B	CUT OFF C	D	E	DROP F
NH04-04FFX	1/4"	9/16"-18	0.250	2.60	1.52	5/8"	11/16"	
NH04-06FFX	1/4"	11/16"-16	0.250	2.65	1.52	5/8"	11/16"	
NH06-06FFX	3/8"	11/16"-16	0.375	2.92	1.61	3/4"	13/16"	
NH06-08FFX	3/8"	13/16"-16	0.375	3.22	1.72	7/8"	15/16"	
NH08-08FFX	1/2"	13/16"-16	0.375	3.29	1.72	7/8"	15/16"	
NH08-10FFX	1/2"	1"-14	0.500	3.29	1.72	7/8"	15/16"	
NH08-12FFX	1/2"	13/16"-16	0.500	3.35	1.95	1-1/8"	1-3/8"	
NH10-10FFX	5/8"	1"-14	0.625	3.29	1.72	7/8"	15/16"	
NH10-12FFX	5/8"	1-3/16"-12	0.625	3.71	1.95	1-1/8"	1-3/8"	
NH12-12FFX	3/4"	1-3/16"-12	0.750	3.71	1.95	1-1/8"	1-3/8"	
NH12-16FFX	3/4"	1-7/16"-12	0.750	3.71	1.95	1-1/8"	1-5/8"	
NH16-16FFX	1"	1-7/16"-12	1.000	4.36	2.11	1-3/8"	1-5/8"	

O-RING FACE SEAL FEMALE 45 TUBE SWIVEL

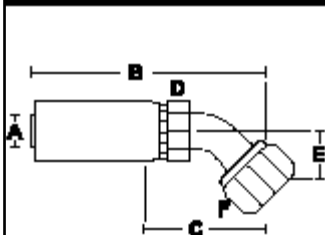

PART NUMBER	HOSE I.D.	THREAD	BARB A	O.A.L B	CUT OFF C	D	DROP E	F
NH04-04FFX45	1/4"	9/16"-18	0.250	2.55	1.47	5/8"	0.41	11/16"
NH04-06FFX45	1/4"	11/16"-16	0.250	2.65	1.51	3/4"	0.43	13/16"
NH06-06FFX45	3/8"	11/16"-16	0.375	2.83	1.51	3/4"	0.43	13/16"
NH06-08FFX45	3/8"	13/16"-16	0.375	3.15	1.75	7/8"	0.59	15/16"
NH08-08FFX45	1/2"	13/16"-16	0.500	3.32	1.75	7/8"	0.59	15/16"
NH08-10FFX45	1/2"	1"-14	0.500	3.58	2.22	7/8"	0.69	1-1/8"
NH10-10FFX45	5/8"	1"-14	0.625	3.61	2.22	7/8"	0.69	1-1/8"
NH10-12FFX45	5/8"	1-3/16"-12	0.625	4.11	2.57	1-1/8"	0.83	1-3/8"
NH12-12FFX45	3/4"	1-3/16"-12	0.750	4.33	2.57	1-1/8"	0.83	1-3/8"
NH16-16FFX45	1"	1-7/16"-12	1.000	4.55	2.84	1-3/8"	0.97	1-5/8"

NATIONAL HOSE

"NH" SERIES CRIMP COUPLINGS FOR BRAIDED HYDRAULIC HOSES

O-RING FACE SEAL FEMALE 90° TUBE SWIVEL

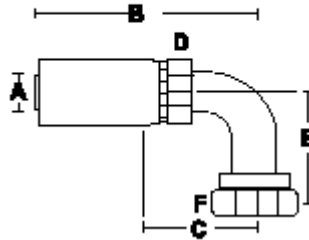

PART NUMBER	HOSE I.D.	THREAD	BARB A	O.A.L B	CUT OFF C	D	DROP E	F
NH04-04FFX90	1/4"	9/16"-18	0.250	2.31	1.23	5/8"	0.78	11/16"
NH04-06FFX90	1/4"	11/16"-16	0.250	2.65	1.43	3/4"	0.90	13/16"
NH06-06FFX90	3/8"	11/16"-16	0.375	2.74	1.43	3/4"	0.90	13/16"
NH06-08FFX90	3/8"	13/16"-16	0.375	2.85	1.48	7/8"	1.15	15/16"
NH08-08FFX90	1/2"	13/16"-16	0.500	3.04	1.48	7/8"	1.15	15/16"
NH08-10FFX90	1/2"	1"-14	0.500	3.47	2.13	7/8"	1.33	1-1/8"
NH10-10FFX90	5/8"	1"-14	0.625	3.47	2.13	7/8"	1.33	1-1/8"
NH10-12FFX90	5/8"	1-3/16"-12	0.625	3.57	2.02	1-1/8"	1.88	1-3/8"
NH12-12FFX90	3/4"	1-3/16"-12	0.750	3.78	2.02	1-1/8"	1.88	1-3/8"
NH12-16FFX90	3/4"	1-7/16"-11	0.750	3.78	2.02	1-1/8"	1.88	1-5/8"
NH16-16FFX90	1"	1-7/16"-12	1.000	4.45	2.84	1-3/8"	2.25	1-5/8"

O-RING FACE SEAL FEMALE 90° SWIVEL LONG DROP

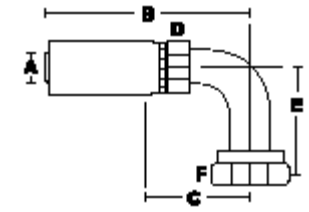

PART NUMBER	HOSE I.D.	THREAD	BARB A	O.A.L B	CUT OFF C	D	DROP E	F
NH04-04FFX90L	1/4"	9/16"-18	0.250	2.31	1.23	5/8"	1.80	9/16"
NH06-06FFX90L	3/8"	11/16"-16	0.375	2.74	1.43	3/4"	2.18	11/16"
NH08-08FFX90L	1/2"	13/16"-16	0.500	3.04	1.48	7/8"	2.43	7/8"
NH12-12FFX90L	3/4"	1-3/16"-12	0.750	3.78	2.02	1-1/8"	2.73	1-1/4"

MALE FACE SEAL RIGID

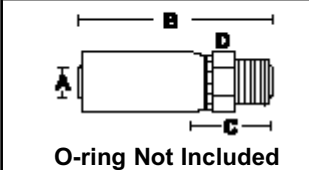

O-ring Not Included

PART NUMBER	HOSE I.D.	THREAD	BARB A	O.A.L B	CUT OFF C	D	E	DROP F
NH04-04MF	1/4"	9/16"-18	0.250	2.36	1.00	5/8"		
NH06-06MF	3/8"	11/16"-16	0.375	2.48	1.13	3/4"		
NH08-08MF	1/2"	13/16"-16	0.500	2.71	1.35	7/8"		
NH10-10MF	5/8"	1"-14	0.625	2.91	1.62	1"		
NH12-12MF	3/4"	1-3/16"-12	0.750	3.12	1.86	1-1/4"		

FLARELESS COMPRESSION SAE J514

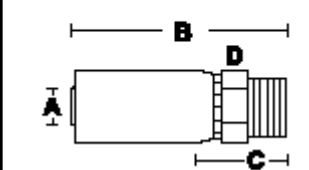

Compression Nut & Sleeve Are Included

PART NUMBER	HOSE I.D.	THREAD	BARB A	O.A.L B	CUT OFF C	D	E	DROP F
NH04-04MT	1/4"	7/16"-20	0.250	2.11	1.03	5/8"		
NH04-05MT	1/4"	1/2"-20	0.250	2.11	1.03	5/8"		
NH06-05MT	3/8"	1/2"-20	0.375	2.42	1.00	3/4"		
NH06-06MT	3/8"	9/16"-18	0.375	2.42	1.00	3/4"		
NH06-08MT	3/8"	3/4"-16	0.375	2.42	1.00	3/4"		
NH08-08MT	1/2"	3/4"-16	0.500	2.42	1.00	3/4"		
NH08-10MT	1/2"	7/8"-14	0.500	2.84	1.16	1-1/16"		
NH12-12MT	3/4"	1-1/16"-12	0.750	3.06	1.25	1-1/4"		
NH16-16MT	1"	1-5/16"-12	1.000	3.62	1.30	1-1/2"		

NATIONAL HOSE

"NH" SERIES CRIMP COUPLINGS FOR BRAIDED HYDRAULIC HOSES

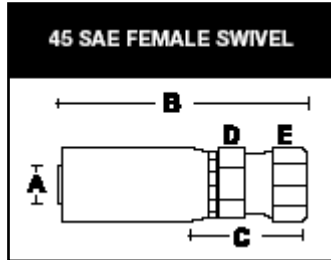

PART NUMBER	HOSE I.D.	THREAD	BARB A	O.A.L B	CUT OFF C	D	E	DROP F
NH04-06FSX	1/4"	5/8"-18	0.250	2.81	1.38	5/8"	15/16"	
NH06-06FSX	3/8"	5/8"-18	0.375	2.81	1.38	3/4"	15/16"	
NH12-12FSX	3/4"	1-1/16"-14	0.750	3.44	1.63	1-1/8"	1-1/4"	

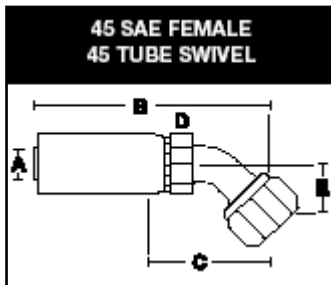

PART NUMBER	HOSE I.D.	THREAD	BARB A	O.A.L B	CUT OFF C	D	DROP E	F
NH06-06FSX45	3/8"	5/8"-18	0.375	2.92	1.50	3/4"	0.58	3/4"
NH12-12FSX45	3/4"	1-1/16"-14	0.750	4.33	2.44	1-1/8"	1.18	1-1/4"

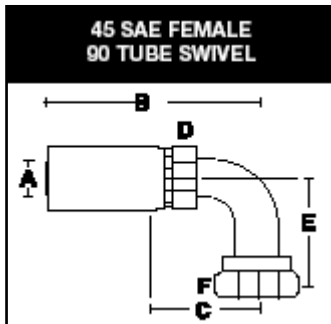

PART NUMBER	HOSE I.D.	THREAD	BARB A	O.A.L B	CUT OFF C	D	DROP E	F
NH06-06FSX90	3/8"	5/8"-18	0.375	2.60	1.20	3/4"	1.12	3/4"
NH12-12FSX90	3/4"	1-1/16"-14	0.750	3.88	2.06	1-1/8"	2.31	1-1/4"

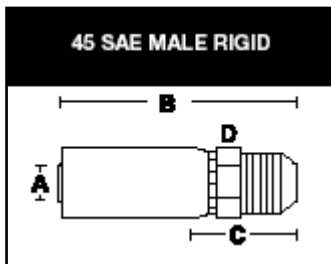

PART NUMBER	HOSE I.D.	THREAD	BARB A	O.A.L B	CUT OFF C	D	E	DROP F
NH06-06MS	3/8"	5/8"-18	0.375	2.65	1.21	3/4"		
NH12-12MS	3/4"	1-1/16"-14	0.750	3.32	1.50	1-1/8"		

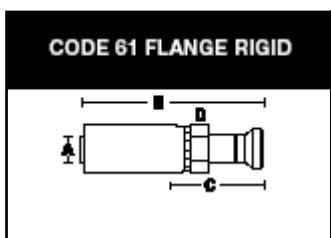

PART NUMBER	HOSE I.D.	FLANGE	BARB A	O.A.L B	CUT OFF C	DROP E	FLANGE O.D. (inch)	FLANGE THICKNESS
NH08-08C61	1/2"	1/2"	0.500	3.65	2.02		1.19	0.265
NH12-12C61	3/4"	3/4"	0.750	4.15	2.33		1.50	0.265
NH16-16C61	1"	1"	1.000	4.66	3.25		1.75	0.315
NH16-20C61	1"	1-1/4"	1.000	4.75	3.35		2.00	0.315

NATIONAL HOSE

"NH" SERIES CRIMP COUPLINGS FOR BRAIDED HYDRAULIC HOSES

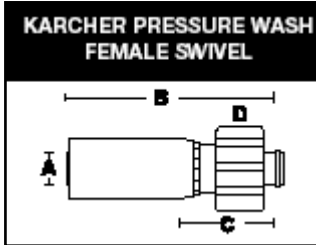

PART NUMBER	HOSE I.D.	THREAD	BARB A	O.A.L B	CUT OFF C	D	E	DROP F
NH04-22KAR	1/4"	M22 X 1.5	0.250	2.65	1.40			
NH06-22KAR	3/8"	M22 X 1.5	0.375	2.86	1.40			

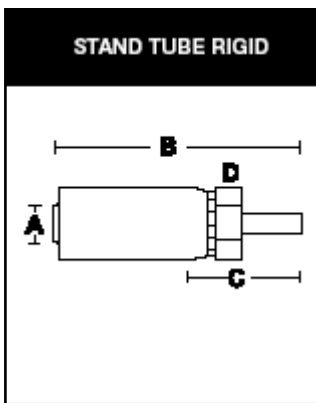

PART NUMBER	HOSE I.D.	TUBE O.D.	BARB A	O.A.L B	CUT OFF C	D	E	DROP F
NH04-04MW	1/4"	0.250	0.250			5/8"		
NH04-05MW	1/4"	0.312	0.250			5/8"		
NH04-06MW	1/4"	0.375	0.250			5/8"		
NH06-06MW	3/8"	0.375	0.375			3/4"		
NH06-08MW	3/8"	0.500	0.375			3/4"		
NH08-08MW	1/2"	0.500	0.500			7/8"		
NH08-10MW	1/2"	0.625	0.500			7/8"		
NH12-12MW	3/4"	0.750	0.750			1-1/8"		
NH16-16MW	1"	1.000	1.000			1-1/4"		

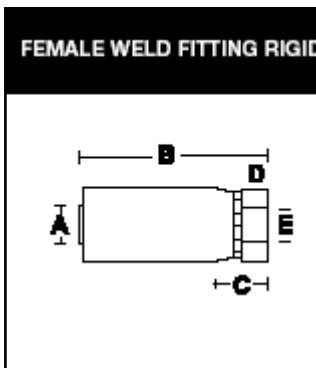



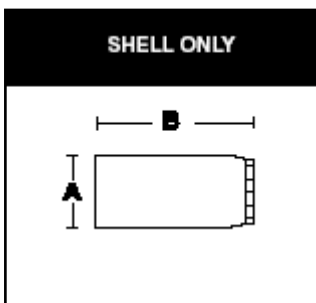

PART NUMBER	HOSE I.D.	SOCKET	BARB A	O.A.L B	CUT OFF C	D	E	DROP F
NH04-04FW	1/4"	0.250	0.250			5/8"		
NH04-05FW	1/4"	0.312	0.250			5/8"		
NH04-06FW	1/4"	0.375	0.250			5/8"		
NH06-06FW	3/8"	0.375	0.375			3/4"		
NH06-08FW	3/8"	0.500	0.375			3/4"		
NH08-08FW	1/2"	0.500	0.500			7/8"		
NH12-12FW	3/4"	0.750	0.750			1"		
NH16-16FW	1"	1.000	1.000			1-1/4"		







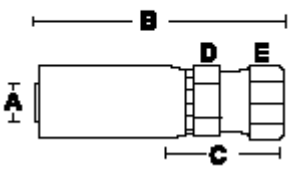

PART NUMBER	HOSE I.D.	THREAD	SHELL O.D. A	O.A.L B	CUT OFF C	D	E	DROP F
SHELL-04	1/4"	N/A	0.750	1.52				
SHELL-06	3/8"	N/A	0.905	1.70				
SHELL-08	1/2"	N/A	1.065	1.90				
SHELL-10	5/8"	N/A	1.310	2.08				
SHELL-12	3/4"	N/A	1.380	2.08				
SHELL-16	1"	N/A	1.790	2.52				

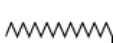

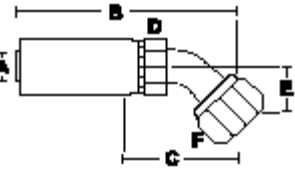

NATIONAL HOSE

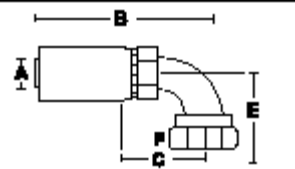

"NH" SERIES CRIMP COUPLINGS FOR BRAIDED HYDRAULIC HOSES

BRITISH STANDARD PIPE 60 CONE FEMALE SWIVEL	PART NUMBER			BARB A	O.A.L B	CUT OFF C			DROP F
		HOSE I.D.	THREAD				D	E	
	NH04-04BSPX	1/4"	1/4"-19	0.250	2.60	1.43			
	NH06-06BSPX	3/8"	3/8"-19	0.375	2.92	1.45			
	NH06-08BSPX	3/8"	1/2"-14	0.375	3.13	1.50			
	NH08-08BSPX	1/2"	1/2"-14	0.500	3.29	1.50			
	NH10-10BSPX	5/8"	5/8"-14	0.625	3.36	1.55			
	NH12-12BSPX	3/4"	3/4"-14	0.750	3.44	1.63			
NH16-16BSPX	1"	1"-11	1.000	4.06	1.69				

BRITISH STANDARD PIPE 60 CONE 45 TUBE FEMALE SWIVEL	PART NUMBER			BARB A	O.A.L B	CUT OFF C		DROP E	
		HOSE I.D.	THREAD				D		F
	NH04-04BSPX45	1/4"	1/4"-19	0.250					
	NH06-06BSPX45	3/8"	3/8"-19	0.375					
	NH08-08BSPX45	1/2"	1/2"-14	0.500					
	NH10-10BSPX45	5/8"	5/8"-14	0.625					
	NH12-12BSPX45	3/4"	3/4"-14	0.750					
	NH16-16BSPX45	1"	1"-11	1.000					

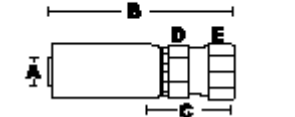

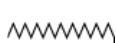
BRITISH STANDARD PIPE 60 CONE 90 TUBE FEMALE SWIVEL	PART NUMBER			BARB A	O.A.L B	CUT OFF C		DROP E	
		HOSE I.D.	THREAD				D		F
	NH04-04BSPX90	1/4"	1/4"-19	0.250					
	NH06-06BSPX90	3/8"	3/8"-19	0.375					
	NH08-08BSPX90	1/2"	1/2"-14	0.500					
	NH10-10BSPX90	5/8"	5/8"-14	0.625					
	NH12-12BSPX90	3/4"	3/4"-14	0.750					
	NH16-16BSPX90	1"	1"-11	1.000					

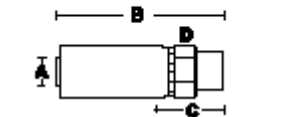

BRITISH FLAT FACE SEAT FEMALE SWIVEL	PART NUMBER			BARB A	O.A.L B	CUT OFF C			DROP F
		HOSE I.D.	THREAD				D	E	
	NH06-06BFPX	3/8"	3/8"-19	0.375	2.92	1.61			
	NH06-08BFPX	3/8"	1/2"-14	0.375	3.13	1.72			
	NH08-08BFPX	1/2"	1/2"-14	0.500	3.29	1.72			

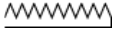

BRITISH PARALLEL PIPE 60 CONE MALE RIGID	PART NUMBER			BARB A	O.A.L B	CUT OFF C			DROP F
		HOSE I.D.	THREAD				D	E	
	NH04-04BSPP	1/4"	1/4"-19	0.250	2.31	1.25			
	NH06-06BSPP	3/8"	3/8"-19	0.375	2.40	1.31			
	NH08-08BSPP	1/2"	1/2"-14	0.500	2.63	1.38			

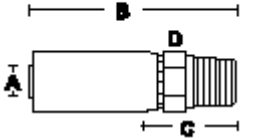

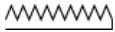
NATIONAL HOSE

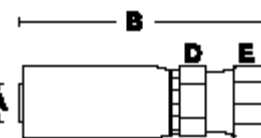

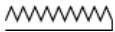

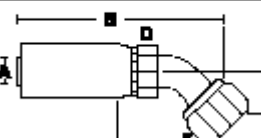
"NH" SERIES CRIMP COUPLINGS FOR BRAIDED HYDRAULIC HOSES

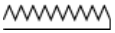
BRITISH STANDARD PIPE 60 CONE MALE RIGID	PART NUMBER			BARB A	O.A.L B	CUT OFF C			DROP F
		HOSE I.D.	THREAD				D	E	
	NH04-04BSPT	1/4"	1/4"-19	0.250	2.31	1.25			
	NH06-06BSPT	3/8"	3/8"-19	0.375	2.40	1.31			
	NH08-08BSPT	1/2"	1/2"-14	0.500	2.63	1.38			
	NH12-12BSPT	3/4"	3/4"-14	0.750	3.22	1.38			
	NH16-16BSPT	1"	1"-11	1.000	3.97	1.56			

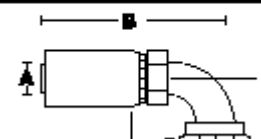
DIN LIGHT UNIVERSAL SEAT FEMALE SWIVEL	PART NUMBER			BARB A	O.A.L B	CUT OFF C			DROP F
		HOSE I.D.	THREAD				D	E	
	NH04-14DINLX	1/4"	M14 X 1.5	0.250					
	NH04-16DINLX	1/4"	M16 X 1.5	0.250					
	NH06-18DINLX	3/8"	M18 X 1.5	0.375					
	NH08-22DINLX	1/2"	M22 X 1.5	0.500					
	NH10-26DINLX	5/8"	M26 X 1.5	0.625					
	NH12-30DINLX	3/4"	M30 X 2.0	0.750					
	NH16-36DINLX	1"	M36 X 2.0	1.000					

DIN LIGHT UNIVERSAL SEAT 45 TUBE FEMALE SWIVEL	PART NUMBER			BARB A	O.A.L B	CUT OFF C		DROP	
		HOSE I.D.	THREAD				E	F	
	NH04-14DINLX45	1/4"	M14 X 1.5	0.250					
	NH06-18DINLX45	3/8"	M18 X 1.5	0.375					
	NH08-22DINLX45	1/2"	M22 X 1.5	0.500					
	NH10-26DINLX45	5/8"	M26 X 1.5	0.625					
	NH12-30DINLX45	3/4"	M30 X 2.0	0.750					
	NH16-36DINLX45	1"	M36 X 2.0	1.000					

DIN LIGHT UNIVERSAL SEAT 90 TUBE FEMALE SWIVEL	PART NUMBER			BARB A	O.A.L B	CUT OFF C		DROP	
		HOSE I.D.	THREAD				D	E	F
	NH04-14DINLX90	1/4"	M14 X 1.5	0.250					
	NH06-18DINLX90	3/8"	M18 X 1.5	0.375					
	NH08-22DINLX90	1/2"	M22 X 1.5	0.500					
	NH10-26DINLX90	5/8"	M26 X 1.5	0.625					
	NH12-30DINLX90	3/4"	M30 X 2.0	0.750					
	NH16-36DINLX90	1"	M36 X 2.0	1.000					

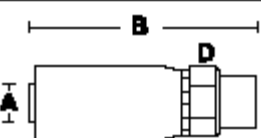
DIN LIGHT UNIVERSAL SEAT RIGID MALE	PART NUMBER			BARB A	O.A.L B	CUT OFF C			DROP F
		HOSE I.D.	THREAD				D	E	
	NH04-14DINL	1/4"	M14 X 1.5	0.250					
	NH06-18DINL	3/8"	M18 X 1.5	0.375					
	NH08-22DINL	1/2"	M22 X 1.5	0.500					
	NH10-26DINL	5/8"	M26 X 1.5	0.625					
	NH12-30DINL	3/4"	M30 X 2.0	0.750					
	NH16-36DINL	1"	M36 X 2.0	1.000					

NATIONAL HOSE

"NH" SERIES CRIMP COUPLINGS FOR BRAIDED HYDRAULIC HOSES

DIN HEAVY UNIVERSAL SEAT FEMALE SWIVEL

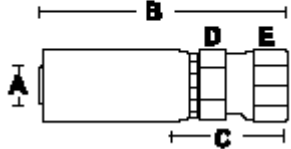

PART NUMBER	HOSE I.D.	THREAD	BARB A	O.A.L B	CUT OFF C	D	E	DROP F
NH04-16DINHX	1/4"	M16 X 1.5	0.250					
NH04-18DINHX	1/4"	M18 X 1.5	0.250					
NH06-22DINHX	3/8"	M22 X 1.5	0.375					
NH08-24DINHX	1/2"	M24 X 1.5	0.500					
NH10-30DINHX	5/8"	M30 X 2.0	0.625					
NH12-36DINHX	3/4"	M36 X 2.0	0.750					
NH16-42DINHX	1"	M42 X 2.0	1.000					

DIN HEAVY UNIVERSAL SEAT 45 TUBE FEMALE SWIVEL

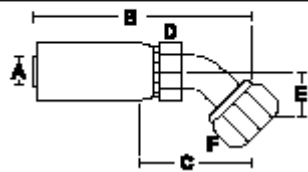

PART NUMBER	HOSE I.D.	THREAD	BARB A	O.A.L B	CUT OFF C	D	DROP E	F
NH04-16DINHX45	1/4"	M16 X 1.5	0.250					
NH06-22DINHX45	3/8"	M22 X 1.5	0.375					
NH08-24DINHX45	1/2"	M24 X 1.5	0.500					
NH10-30DINHX45	5/8"	M30 X 2.0	0.625					
NH12-36DINHX45	3/4"	M36 X 2.0	0.750					
NH16-42DINHX45	1"	M42 X 2.0	1.000					

DIN HEAVY UNIVERSAL SEAT 90 TUBE FEMALE SWIVEL

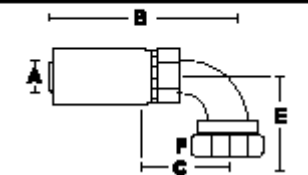

PART NUMBER	HOSE I.D.	THREAD	BARB A	O.A.L B	CUT OFF C	D	DROP E	F
NH04-16DINHX90	1/4"	M16 X 1.5	0.250					
NH06-22DINHX90	3/8"	M22 X 1.5	0.375					
NH08-24DINHX90	1/2"	M24 X 1.5	0.500					
NH10-30DINHX90	5/8"	M30 X 2.0	0.625					
NH12-36DINHX90	3/4"	M36 X 2.0	0.750					
NH16-42DINHX90	1"	M42 X 2.0	1.000					

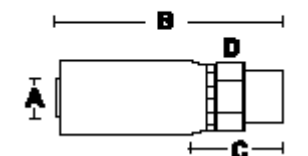

DIN HEAVY UNIVERSAL SEAT RIGID MALE



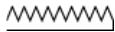

PART NUMBER	HOSE I.D.	THREAD	BARB A	O.A.L B	CUT OFF C	D	E	DROP F
NH04-16DINH	1/4"	M16 X 1.5	0.250					
NH04-18DINH	1/4"	M18 X 1.5	0.250					
NH06-22DINH	3/8"	M22 X 1.5	0.375					
NH08-24DINH	1/2"	M24 X 1.5	0.500					
NH10-30DINH	5/8"	M30 X 2.0	0.625					
NH12-36DINH	3/4"	M36 X 2.0	0.750					
NH16-42DINH	1"	M42 X 2.0	1.000					

NATIONAL HOSE

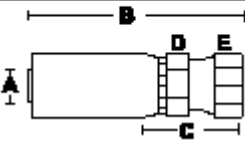

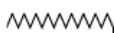
"NH" SERIES CRIMP COUPLINGS FOR BRAIDED HYDRAULIC HOSES

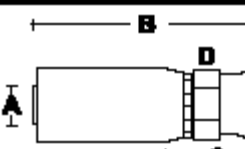

JIS 30 SEAT FEMALE SWIVEL				BARB A	O.A.L B	CUT OFF C			DROP F
		HOSE I.D.	THREAD				D	E	F
NH04-04JISX	1/4"	1/4"-19	0.250	2.60	1.40				
NH06-06JISX	3/8"	3/8"-19	0.375	2.92	1.42				
NH08-08JISX	1/2"	1/2"-14	0.500	3.13	1.50				
NH12-12JISX	3/4"	3/4"-14	0.750	3.44	1.63				
NH16-16JISX	1"	1"-11	1.000	4.06	1.69				

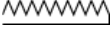

KOMATSU JIS 30 SEAT FEMALE SWIVEL				BARB A	O.A.L B	CUT OFF C			DROP F
		HOSE I.D.	THREAD				D	E	F
NH04-04KOMX	1/4"	M14 X 1.5	0.250	2.60	1.40				
NH06-06KOMX	3/8"	M18 X 1.5	0.375	2.92	1.43				
NH08-08KOMX	1/2"	M22 X 1.5	0.500	3.13	1.50				
NH10-10KOMX	5/8"	M24 X 1.5	0.625	3.36	1.50				
NH12-12KOMX	3/4"	M30 X 1.5	0.750	3.44	1.63				
NH16-16KOMX	1"	M33 X 1.5	1.000	4.06	1.69				

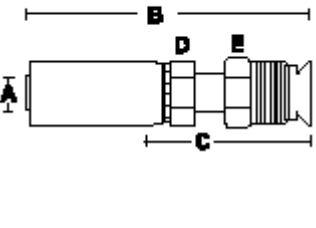
NATIONAL HOSE

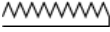
"NH" SERIES CRIMP COUPLINGS FOR BRAIDED HYDRAULIC HOSES

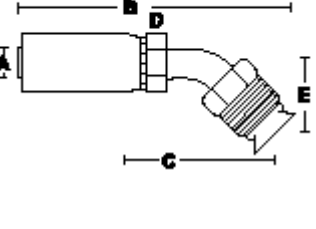

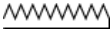
45° SAE MALE INVERTED FLARE	PART NUMBER			BARB A	O.A.L B	CUT OFF C			DROP F
		HOSE I.D.	THREAD				D	E	
	NH04-04MIX	1/4"	7/16"-24	0.250	3.28				
	NH04-05MIX	1/4"	1/2"-20	0.250	3.28				
	NH04-06MIX	1/4"	5/8"-18	0.250	3.45				
	NH06-05MIX	3/8"	1/2"-20	0.375	3.73				
	NH06-06MIX	3/8"	5/8"-18	0.375	3.73				
	NH06-08MIX	3/8"	3/4"-18	0.375	3.42				
	NH08-08MIX	1/2"	3/4"-18	0.500	3.66				

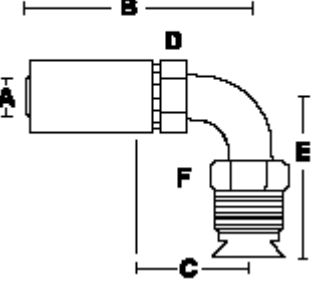

45° SAE MALE INVERTED FLARE 45°	PART NUMBER			BARB A	O.A.L B	CUT OFF C		DROP E	
		HOSE I.D.	THREAD				D		F
	NH04-04MIX45	1/4"	7/16"-24	0.250					
	NH04-05MIX45	1/4"	1/2"-20	0.250					
	NH04-06MIX45	1/4"	5/8"-18	0.250					
	NH06-05MIX45	3/8"	1/2"-20	0.375					
	NH06-06MIX45	3/8"	5/8"-18	0.375					
	NH06-08MIX45	3/8"	3/4"-18	0.375					
	NH08-08MIX45	1/2"	3/4"-18	0.500					

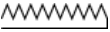

45° SAE MALE INVERTED FLARE 90°	PART NUMBER			BARB A	O.A.L B	CUT OFF C		DROP E	
		HOSE I.D.	THREAD				D		F
	NH04-04MIX90	1/4"	7/16"-24	0.250					
	NH04-05MIX90	1/4"	1/2"-20	0.250					
	NH04-06MIX90	1/4"	5/8"-18	0.250					
	NH06-05MIX90	3/8"	1/2"-20	0.375					
	NH06-06MIX90	3/8"	5/8"-18	0.375					
	NH06-08MIX90	3/8"	3/4"-18	0.375					
	NH08-08MIX90	1/2"	3/4"-18	0.500					

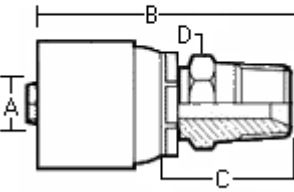

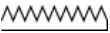
NATIONAL HOSE

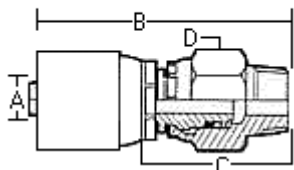
"TC" SERIES CRIMP COUPLINGS FOR BRAIDED & SPIRAL HYDRAULIC HOSES

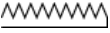
MALE NPT RIGID	PART NUMBER			BARB A	O.A.L B	CUT OFF C			DROP F
		HOSE I.D.	THREAD				D	E	
	TC04-04MP	1/4"	1/4"-18	0.250		1.03	9/16"		
	TC04-06MP	1/4"	3/8"-18	0.250		1.08	11/16"		
	TC06-06MP	3/8"	3/8"-18	0.375		1.09	11/16"		
	TC06-08MP	3/8"	1/2"-14	0.375		1.31	7/8"		
	TC08-08MP	1/2"	1/2"-14	0.500		1.34	7/8"		
	TC10-08MP	5/8"	1/2"-14	0.625		1.42	1"		
	TC10-12MP	5/8"	3/4"-14	0.625		1.46	1-1/8"		
	TC12-12MP	3/4"	3/4"-14	0.750		1.47	1-1/8"		
	TC16-16MP	1"	1"-11 1/2"	1.000		1.76	1-7/16"		

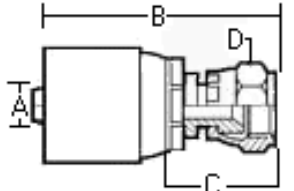
MALE NPT SWIVEL	PART NUMBER			BARB A	O.A.L B	CUT OFF C			DROP F
		HOSE I.D.	THREAD				D	E	
	TC04-04MPX	1/4"	1/4"-18	0.250		1.51	11/16"		
	TC06-06MPX	3/8"	3/8"-18	0.375		1.53	13/16"		
	TC08-08MPX	1/2"	1/2"-14	0.500		1.82	1"		
	TC12-12MPX	3/4"	3/4"-14	0.750		1.90	1-1/4"		
	TC16-16MPX	1"	1"-11 1/2"	1.000		2.20	1-1/2"		

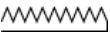
37° FEMALE JIC SWIVEL	PART NUMBER			BARB A	O.A.L B	CUT OFF C			DROP F
		HOSE I.D.	THREAD				D	E	
	TC04-04FJX	1/4"	7/16"-20	0.250		0.59	9/16"		
	TC04-06FJX	1/4"	9/16"-18	0.250		0.65	11/16"		
	TC06-06FJX	3/8"	9/16"-18	0.375		0.65	11/16"		
	TC06-08FJX	3/8"	3/4"-16	0.375		0.73	15/16"		
	TC08-08FJX	1/2"	3/4"-16	0.500		0.76	15/16"		
	TC08-10FJX	1/2"	7/8"-14	0.500		0.80	1-1/16"		
	TC10-10FJX	5/8"	7/8"-14	0.625		0.80	1-1/16"		
	TC12-12FJX	3/4"	1-1/16"-12	0.750		0.86	1-1/4"		
	TC16-16FJX	1"	1-5/16"-12	1.000		0.95	1-1/2"		

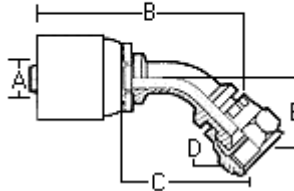
37° FEMALE JIC 45° TUBE SWIVEL	PART NUMBER			BARB A	O.A.L B	CUT OFF C		DROP E	
		HOSE I.D.	THREAD				D	F	
	TC04-04FJX45	1/4"	7/16"-20	0.250		1.43	9/16"	0.640	
	TC06-06FJX45	3/8"	9/16"-18	0.375		1.47	11/16"	0.650	
	TC08-08FJX45	1/2"	3/4"-16	0.500		1.60	15/16"	0.810	
	TC08-10FJX45	1/2"	7/8"-14	0.500		1.68	1-1/16"	0.890	
	TC10-10FJX45	5/8"	7/8"-14	0.625		1.91	1-1/16"	0.900	
	TC12-12FJX45	3/4"	1-1/16"-12	0.750		1.94	1-1/4"	0.820	
	TC16-16FJX45	1"	1-5/16"-12	1.000		2.32	1-1/2"	0.950	

NATIONAL HOSE

"TC" SERIES CRIMP COUPLINGS FOR BRAIDED & SPIRAL HYDRAULIC HOSES

37° FEMALE JIC 90° TUBE SWIVEL

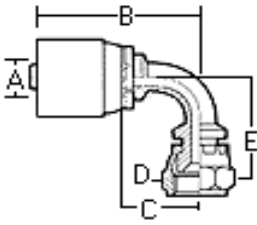

PART NUMBER

HOSE I.D.

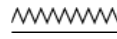

THREAD

BARB
A

O.A.L
B

CUT OFF
C



D

DROP
E



F

TC04-04FJX90
TC06-06FJX90
TC08-08FJX90
TC08-10FJX90
TC10-10FJX90
TC12-12FJX90
TC16-16FJX90

1/4"
3/8"
1/2"
1/2"
5/8"
3/4"
1"

7/16"-20
9/16"-18
3/4"-16
7/8"-14
7/8"-14
1-1/16"-12
1-5/16"-12

0.250
0.375
0.500
0.500
0.625
0.750
1.000

1.07
1.24
1.31
1.31
1.72
1.78
2.32

9/16"
11/16"
15/16"
1-1/16"
1-1/16"
1-1/4"
1-1/2"

1.180
1.350
1.660
1.760
2.200
1.820
2.210

37° MALE JIC RIGID

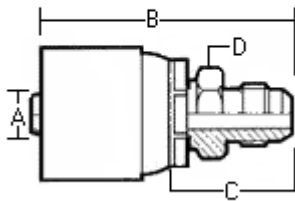

PART NUMBER

HOSE I.D.

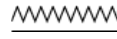

THREAD

BARB
A

O.A.L
B

CUT OFF
C



D

E

DROP
F

TC04-04MJ
TC04-06MJ
TC06-06MJ
TC06-08MJ
TC08-08MJ
TC08-10MJ
TC10-10MJ
TC12-12MJ
TC16-16MJ

1/4"
1/4"
3/8"
3/8"
1/2"
1/2"
5/8"
3/4"
1"

7/16"-20
9/16"-18
9/16"-18
3/4"-16
3/4"-16
7/8"-14
7/8"-14
1-1/16"-12
1-5/16"-12

0.250
0.250
0.375
0.375
0.500
0.500
0.625
0.750
1.000

1.00
1.03
1.05
1.20
1.25
1.35
1.40
1.54
1.73

1/2"
9/16"
5/8"
3/4"
13/16"
7/8"
15/16"
1-1/16"
1-3/8"

MALE BOSS-ORING RIGID

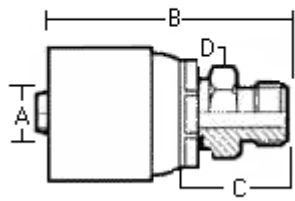

PART NUMBER

HOSE I.D.

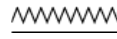

THREAD

BARB
A

O.A.L
B

CUT OFF
C



D

E

DROP
F

TC04-04MB
TC06-06MB
TC06-08MB
TC08-08MB
TC08-10MB
TC10-10MB
TC12-12MB
TC16-16MB

1/4"
1/4"
3/8"
1/2"
1/2"
5/8"
3/4"
1"

7/16"-20
9/16"-18
3/4"-16
3/4"-16
7/8"-14
7/8"-14
1-1/16"-12
1-5/16"-12





0.250
0.375
0.375
0.500
0.500
0.625
0.750
1.000





0.83
0.92
0.99
1.03
1.16
1.16
1.33
1.47

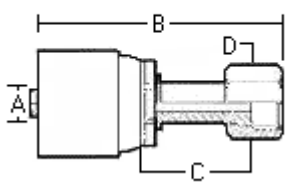

9/16"
11/16"
7/8"
7/8"
1"
1"
1-1/4"
1-1/2"

NATIONAL HOSE

"TC" SERIES CRIMP COUPLINGS FOR BRAIDED & SPIRAL HYDRAULIC HOSES

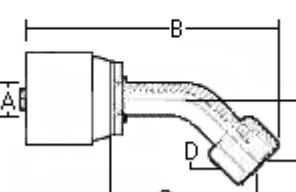

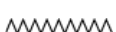
O-RING FACE SEAL FEMALE SWIVEL	PART NUMBER			BARB A	O.A.L B	CUT OFF C			DROP F
		HOSE I.D.	THREAD				D	E	
	TC04-04FFX	1/4"	9/16"-18	0.250		1.01	11/16"		
	TC06-06FFX	3/8"	11/16"-16	0.375		1.10	13/16"		
	TC08-08FFX	1/2"	13/16"-16	0.500		1.30	15/16"		
	TC10-10FFX	5/8"	1"-14	0.625		1.31	1-1/8"		
	TC12-12FFX	3/4"	1-3/16"-12	0.750		1.40	1-3/8"		
	TC16-16FFX	1"	1-7/16"-12	1.000		1.49	1-5/8"		

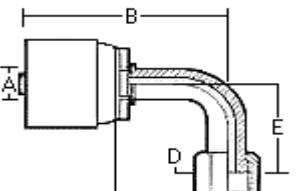

O-RING FACE SEAL FEMALE 45° TUBE SWIVEL	PART NUMBER			BARB A	O.A.L B	CUT OFF C		DROP E	
		HOSE I.D.	THREAD				D		F
	TC04-04FFX45	1/4"	9/16"-18	0.250		1.01	11/16"	0.520	
	TC06-06FFX45	3/8"	11/16"-16	0.375		1.10	13/16"	0.670	
	TC08-08FFX45	1/2"	13/16"-16	0.500		1.30	15/16"	0.850	
	TC10-10FFX45	5/8"	1"-14	0.625		1.31	1-1/8"	1.000	
	TC12-12FFX45	3/4"	1-3/16"-12	0.750		2.01	1-3/8"	0.880	
	TC16-16FFX45	1"	1-7/16"-12	1.000		2.25	1-5/8"	0.890	

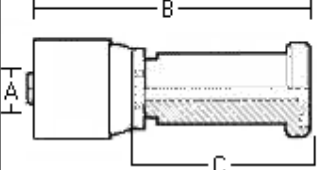

O-RING FACE SEAL FEMALE 90° TUBE SWIVEL	PART NUMBER			BARB A	O.A.L B	CUT OFF C		DROP E	
		HOSE I.D.	THREAD				D		F
	TC04-04FFX90	1/4"	9/16"-18	0.250		1.06	11/16"	1.06	
	TC06-06FFX90	3/8"	11/16"-16	0.375		1.15	13/16"	1.36	
	TC08-08FFX90	1/2"	13/16"-16	0.500		1.50	15/16"	1.67	
	TC10-10FFX90	5/8"	1"-14	0.625		1.67	1-1/8"	2.09	
	TC12-12FFX90	3/4"	1-3/16"-12	0.750		1.78	1-3/8"	1.730	
	TC16-16FFX90	1"	1-7/16"-12	1.000		2.24	1-5/8"	2.150	

NATIONAL HOSE

"TC" SERIES CRIMP COUPLINGS FOR BRAIDED & SPIRAL HYDRAULIC HOSES

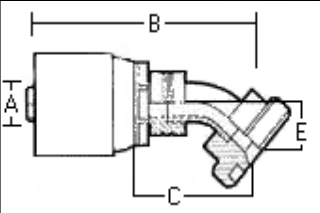

CODE 61 FLANGE RIGID				BARB A	O.A.L B	CUT OFF C	DROP E	FLANGE O.D. (inch)	FLANGE THICKNESS
	PART NUMBER	HOSE I.D.	FLANGE						
	TC08-08C61	1/2"	1/2"	0.500		1.84		1.19	0.265
	TC08-12C61	3/4"	3/4"	0.750		1.46		1.50	0.265
	TC10-12C61	5/8"	3/4"	0.625		1.91		1.50	0.265
	TC12-12C61	3/4"	3/4"	0.750		1.95		1.50	0.265
TC16-16C61	1"	1"	1.000		2.60		1.75	0.315	

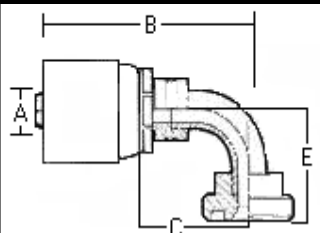

CODE 61 FLANGE 45° RIGID				BARB A	O.A.L B	CUT OFF C	DROP E	FLANGE O.D. (inch)	FLANGE THICKNESS
	PART NUMBER	HOSE I.D.	FLANGE						
	TC08-08C61-45	1/2"	1/2"	0.500		1.49	0.59	1.19	0.265
	TC08-12C61-45	3/4"	3/4"	0.750		1.85	0.77	1.50	0.265
	TC10-12C61-45	5/8"	3/4"	0.625		1.85	0.77	1.50	0.265
	TC12-12C61-45	3/4"	3/4"	0.750		1.89	0.77	1.50	0.265
TC16-16C61-45	1"	1"	1.000		2.26	0.90	1.75	0.315	

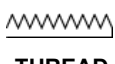

CODE 61 FLANGE 90° RIGID				BARB A	O.A.L B	CUT OFF C	DROP E	FLANGE O.D. (inch)	FLANGE THICKNESS
	PART NUMBER	HOSE I.D.	FLANGE						
	TC08-08C61-90	1/2"	1/2"	0.500		1.31	1.25	1.19	0.265
	TC08-12C61-90	3/4"	3/4"	0.750		1.74	1.74	1.50	0.265
	TC10-12C61-90	5/8"	3/4"	0.625		1.74	1.74	1.50	0.265
	TC12-12C61-90	3/4"	3/4"	0.750		1.78	1.74	1.50	0.265
TC16-16C61-90	1"	1"	1.000		2.23	2.14	1.75	0.315	

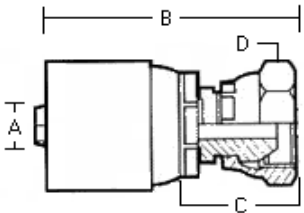

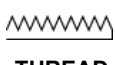
NATIONAL HOSE

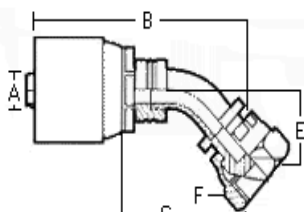
"TC" SERIES CRIMP COUPLINGS FOR BRAIDED & SPIRAL HYDRAULIC HOSES

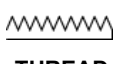
BRITISH STANDARD PIPE 60° CONE FEMALE SWIVEL	PART NUMBER			BARB A	O.A.L B	CUT OFF C			DROP F
		HOSE I.D.	THREAD				D	E	
	TC04-04BSPX	1/4"	1/4"-19	0.250		0.73	23/32"		
	TC06-06BSPX	3/8"	3/8"-19	0.375		0.72	23/32"		
	TC08-08BSPX	1/2"	1/2"-14	0.500		0.83	1-1/64"		
	TC08-10BSPX	1/2"	5/8"-14	0.500		0.80	1-7/64"		
	TC10-08BSPX	5/8"	1/2"-14	0.625		0.83	1-1/64"		
	TC10-10BSPX	5/8"	5/8"-14	0.625		0.80	1-7/64"		
	TC12-12BSPX	3/4"	3/4"-14	0.750		0.89	1-19/64"		
	TC16-16BSPX	1"	1"-11	1.000		0.97	1-31/64"		
	TC20-20BSPX	1-1/4"	1-1/4"-11	1.250		1.06	1-55/64"		
	TC24-24BSPX	1-1/2"	1-1/2"-11	1.500		1.26	2-7/32"		
	TC32-32BSPX	2"	2"-11	2.000		2.76	2-49/64"		

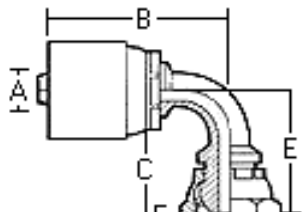
BRITISH STANDARD PIPE 60° CONE 45° TUBE FEMALE SWIVEL	PART NUMBER			BARB A	O.A.L B	CUT OFF C		DROP E	
		HOSE I.D.	THREAD				D	F	
	TC04-04BSPX45	1/4"	1/4"-19	0.250		1.43	23/32"	0.690	
	TC06-06BSPX45	3/8"	3/8"-19	0.375		1.52	23/32"	0.710	
	TC08-08BSPX45	1/2"	1/2"-14	0.500		1.66	1-1/64"	0.870	
	TC08-10BSPX45	1/2"	5/8"-14	0.500		1.75	1-7/64"	0.740	
	TC10-10BSPX45	5/8"	5/8"-14	0.625		1.75	1-7/64"	0.740	
	TC12-12BSPX45	3/4"	3/4"-14	0.750		2.20	1-19/64"	0.920	
	TC16-16BSPX45	1"	1"-11	1.000		2.33	1-31/64"	0.970	
	TC20-20BSPX45	1-1/4"	1-1/4"-11	1.250		2.66	1-55/64"	1.120	
	TC24-24BSPX45	1-1/2"	1-1/2"-11	1.500		3.08	2-7/32"	1.380	
	TC32-32BSPX45	2"	2"-11	2.000		3.72	2-49/64"	1.900	

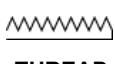
BRITISH STANDARD PIPE 60° CONE 90° TUBE FEMALE SWIVEL	PART NUMBER			BARB A	O.A.L B	CUT OFF C		DROP E	
		HOSE I.D.	THREAD				D	F	
	TC04-04BSPX90	1/4"	1/4"-19	0.250		1.07	23/32"	1.300	
	TC06-06BSPX90	3/8"	3/8"-19	0.375		1.24	23/32"	1.410	
	TC08-08BSPX90	1/2"	1/2"-14	0.500		1.31	1-1/64"	1.750	
	TC08-10BSPX90	1/2"	5/8"-14	0.500		1.56	1-7/64"	1.600	
	TC10-10BSPX90	5/8"	5/8"-14	0.625		1.56	1-7/64"	1.600	
	TC12-12BSPX90	3/4"	3/4"-14	0.750		2.01	1-19/64"	2.040	
	TC16-16BSPX90	1"	1"-11	1.000		2.23	1-31/64"	2.230	
	TC20-20BSPX90	1-1/4"	1-1/4"-11	1.250		2.64	1-55/64"	2.680	
	TC24-24BSPX90	1-1/2"	1-1/2"-11	1.500		3.02	2-7/32"	3.270	
	TC32-32BSPX90	2"	2"-11	2.000		3.88	2-49/64"	4.440	

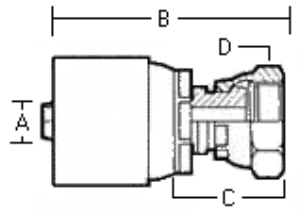
BRITISH FLAT FACE SEAT FEMALE SWIVEL	PART NUMBER			BARB A	O.A.L B	CUT OFF C			DROP F
		HOSE I.D.	THREAD				D	E	
	TC04-04BFPX	1/4"	1/4"-19	0.250		0.52	23/32"		
	TC06-06BFPX	3/8"	3/8"-19	0.375		0.55	53/64"		
	TC06-08BFPX	3/8"	1/2"-14	0.375		0.61	1-1/64"		
	TC08-06BFPX	1/2"	1/2"-14	0.500		0.58	53/64"		
	TC08-08BFPX	1/2"	1/2"-14	0.500		0.63	1-1/64"		
	TC12-12BFPX	3/4"	3/4"-14	0.750		0.72	1-19/64"		
	TC16-16BFPX	1"	1"-11	1.000		0.75	1-31/64"		

NATIONAL HOSE

"TC" SERIES CRIMP COUPLINGS FOR BRAIDED & SPIRAL HYDRAULIC HOSES

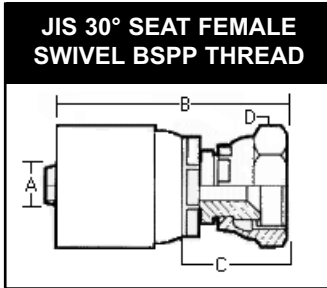

PART NUMBER	HOSE I.D.	THREAD	BARB A	O.A.L B	CUT OFF C	D	E	DROP F
TC04-04JISX	1/4"	1/4"-19	0.250		0.59	19mm		
TC06-06JISX	3/8"	3/8"-19	0.375		0.60	22mm		
TC08-08JISX	1/2"	1/2"-14	0.500		0.70	27mm		
TC12-12JISX	3/4"	3/4"-14	0.750		0.73	32mm		
TC16-16JISX	1"	1"-11	1.000		0.89	41mm		

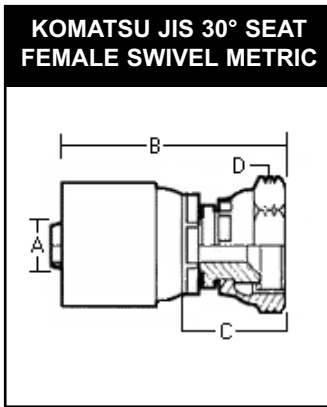



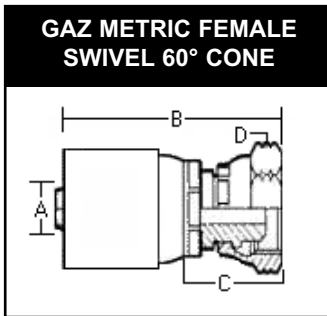

PART NUMBER	HOSE I.D.	THREAD	BARB A	O.A.L B	CUT OFF C	D	E	DROP F
TC04-14KOMX	1/4"	M14 x 1.5	0.250		0.64	19mm		
TC06-18KOMX	3/8"	M18 x 1.5	0.375		0.66	22mm		
TC08-22KOMX	1/2"	M22 x 1.5	0.500		0.79	27mm		
TC08-24KOMX	1/2"	M24 x 1.5	0.500		0.81	30mm		
TC10-24KOMX	5/8"	M24 x 1.5	0.625		0.81	30mm		
TC10-28KOMX	5/8"	M28 x 1.5	0.625		0.84	36mm		
TC12-30KOMX	3/4"	M30 x 1.5	0.750		0.85	36mm		
TC16-33KOMX	1"	M33 x 1.5	1.000		0.91	41mm		
TC20-36KOMX	1-1/4"	M36 x 1.5	1.250		0.97	46mm		





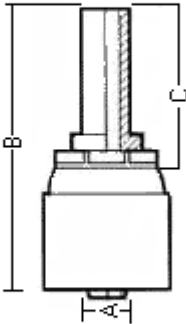

PART NUMBER	HOSE I.D.	THREAD	BARB A	O.A.L B	CUT OFF C	D	E	DROP F
TC06-20GAZX	3/8"	M20 x 1.5	0.375		0.81	24mm		
TC08-24GAZX	1/2"	M24 x 1.5	0.500		1.00	30mm		
TC10-30GAZX	5/8"	M30 x 1.5	0.625		1.03	36mm		
TC12-36GAZX	3/4"	M36 x 1.5	0.750		1.20	46mm		
TC16-45GAZX	1"	M45 x 1.5	1.000		1.39	55mm		

NATIONAL HOSE



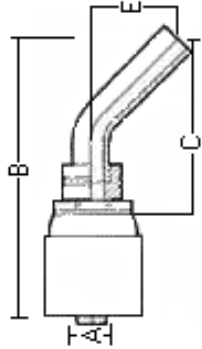

"TC" SERIES CRIMP COUPLINGS FOR BRAIDED & SPIRAL HYDRAULIC HOSES

METRIC O.D. STANDPIPE	PART NUMBER	 HOSE I.D.	 TUBE O.D.	BARB A	O.A.L B	CUT OFF C	 D	 E	DROP F
	TC04-06MSP	1/4"	6mm	0.250		1.13			
	TC04-08MSP	1/4"	8mm	0.250		1.21			
	TC04-10MSP	1/4"	10mm	0.250		1.29			
	TC04-12MSP	1/4"	12mm	0.250		1.29			
	TC06-10MSP	3/8"	10mm	0.375		1.29			
	TC06-12MSP	3/8"	12mm	0.375		1.29			
	TC06-14MSP	3/8"	14mm	0.375		1.40			
	TC08-15MSP	1/2"	15mm	0.500		1.28			
	TC08-16MSP	1/2"	16mm	0.500		1.47			
	TC08-18MSP	1/2"	18mm	0.500		1.32			
	TC10-18MSP	5/8"	18mm	0.625		1.32			
	TC10-20MSP	5/8"	20mm	0.625		1.71			
	TC12-20MSP	3/4"	20mm	0.750		1.73			
	TC12-22MSP	3/4"	22mm	0.750		1.41			
	TC12-25MSP	3/4"	25mm	0.750		1.89			
	TC16-25MSP	1"	25mm	1.000		1.92			
	TC16-28MSP	1"	28mm	1.000		1.53			
	TC16-30MSP	1"	30mm	1.000		2.08			
	TC20-35MSP	1-1/4"	35mm	1.250		1.78			
	TC20-38MSP	1-1/4"	38mm	1.250		2.34			
TC20-42MSP	1-1/4"	42mm	1.250		1.78				

METRIC O.D. 45° TUBE STANDPIPE	PART NUMBER	 HOSE I.D.	 TUBE O.D.	BARB A	O.A.L B	CUT OFF C	 D	DROP E	 F
	TC04-06MSP45	1/4"	6mm	0.250		1.56		0.800	
	TC04-08MSP45	1/4"	8mm	0.250		1.64		0.840	
	TC04-10MSP45	1/4"	10mm	0.250		1.76		0.910	
	TC06-10MSP45	3/8"	10mm	0.375		1.81		0.910	
	TC06-12MSP45	3/8"	12mm	0.375		1.82		0.940	
	TC06-14MSP45	3/8"	14mm	0.375		2.03		1.070	
	TC08-15MSP45	1/2"	15mm	0.500		1.96		0.970	
	TC08-16MSP45	1/2"	16mm	0.500		2.14		1.130	
	TC08-18MSP45	1/2"	18mm	0.500		2.13		1.060	
	TC10-18MSP45	5/8"	18mm	0.625		2.13		1.060	
	TC10-20MSP45	5/8"	20mm	0.625		2.46		1.350	
	TC12-22MSP45	3/4"	22mm	0.750		2.39		1.190	
	TC12-25MSP45	3/4"	25mm	0.750		2.89		1.560	
	TC16-28MSP45	1"	28mm	1.000		2.76		1.320	

NATIONAL HOSE

"TC" SERIES CRIMP COUPLINGS FOR BRAIDED & SPIRAL HYDRAULIC HOSES

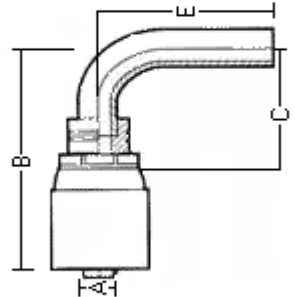

METRIC O.D. 90° TUBE STANDPIPE	PART NUMBER			BARB A	O.A.L B	CUT OFF C		DROP E	
		HOSE I.D.	TUBE O.D.				D		F
	TC04-06MSP90	1/4"	6mm	0.250		0.95		1.340	
	TC04-08MSP90	1/4"	8mm	0.250		1.07		1.460	
	TC04-10MSP90	1/4"	10mm	0.250		1.19		1.630	
	TC06-10MSP90	3/8"	10mm	0.375		1.24		1.630	
	TC06-12MSP90	3/8"	12mm	0.375		1.29		1.750	
	TC06-14MSP90	3/8"	14mm	0.375		1.42		2.010	
	TC08-15MSP90	1/2"	15mm	0.500		1.50		1.890	
	TC08-16MSP90	1/2"	16mm	0.500		1.56		2.150	
	TC08-18MSP90	1/2"	18mm	0.500		1.68		2.130	
	TC10-18MSP90	5/8"	18mm	0.625		1.68		2.130	
	TC10-20MSP90	5/8"	20mm	0.625		1.80		2.600	
	TC12-22MSP90	3/4"	22mm	0.750		1.96		2.440	
	TC12-25MSP90	3/4"	25mm	0.750		2.19		3.070	
	TC16-25MSP90	1"	25mm	1.000		2.23		3.070	
	TC16-28MSP90	1"	28mm	1.000		2.40		2.830	
TC16-30MSP90	1"	30mm	1.000		2.52		3.500		



METRIC COMPRESSION SWIVEL NUT					
	PART NUMBER	FIT'S TUBE O.D.	NUT PRESSURE SERIES	MAX W.P. (PSI)	MAX W.P. (BAR)
M-06-L	6mm	L	7,250	500	14mm
M-08-L	8mm	L	7,250	500	17mm
M-10-L	10mm	L	7,250	500	19mm
M-12-L	12mm	L	5,800	400	22mm
M-15-L	15mm	L	5,800	400	27mm
M-18-L	18mm	L	5,800	400	32mm
M-22-L	22mm	L	3,625	250	36mm
M-28-L	28mm	L	3,625	250	41mm
M-35-L	35mm	L	3,625	250	50mm
M-42-L	42mm	L	3,625	250	60mm
M-06-S	6mm	S	9,135	630	17mm
M-08-S	8mm	S	9,135	630	19mm
M-10-S	10mm	S	9,135	630	22mm
M-12-S	12mm	S	9,135	630	24mm
M-14-S	14mm	S	9,135	630	27mm
M-16-S	16mm	S	9,135	630	30mm
M-20-S	20mm	S	5,800	400	36mm
M-25-S	25mm	S	5,800	400	46mm
M-30-S	30mm	S	5,800	400	50mm
M-38-S	38mm	S	5,800	400	60mm

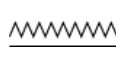

METRIC COMPRESSION BITE RING SLEEVE					
	PART NUMBER	FIT'S TUBE O.D.	SLEEVE PRESSURE SERIES	MAX W.P. (PSI)	MAX W.P. (BAR)
DS-06-L/S	6mm	L & S	9,135	630	
DS-08-L/S	8mm	L & S	9,135	630	
DS-10-L/S	10mm	L & S	9,135	630	
DS-12-L/S	12mm	L & S	9,135	630	
DS-15-L	15mm	L	5,800	400	
DS-18-L	18mm	L	5,800	400	
DS-22-L	22mm	L	3,625	250	
DS-28-L	28mm	L	3,625	250	
DS-35-L	35mm	L	3,625	250	
DS-42-L	42mm	L	3,625	250	
DS-14-S	14mm	S	9,135	630	
DS-16-S	16mm	S	9,135	630	
DS-20-S	20mm	S	5,800	400	
DS-25-S	25mm	S	5,800	400	
DS-30-S	30mm	S	5,800	400	
DS-38-S	38mm	S	5,800	400	

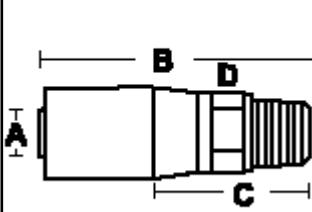
NATIONAL HOSE

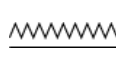
"BW" SERIES CRIMP COUPLINGS FOR BRAIDED & SPIRAL HYDRAULIC HOSES

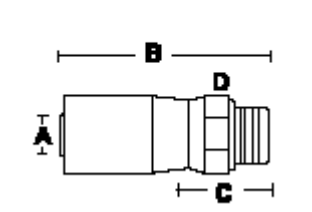

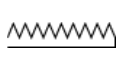
MALE PIPE NPTF RIGID	PART NUMBER			BARB A	O.A.L B	CUT OFF C			DROP F
		HOSE I.D.	THREAD				D	E	
	BW06-06MP	3/8"	3/8"-18	0.375	2.37	0.99	11/16"		
	BW06-08MP	3/8"	1/2"-14	0.370	2.61	1.24	11/16"		
	BW08-08MP	1/2"	1/2"-14	0.500	2.65	1.31	7/8"		
	BW10-08MP	5/8"	1/2"-14	0.625	3.22	1.43	7/8"		
	BW10-12MP	5/8"	3/4"-14	0.625	3.22	1.43	1-1/16"		
	BW12-12MP	3/4"	3/4"-14	0.750	3.29	1.41	1-1/16"		
	BW12-16MP	3/4"	1"-11 1/2	0.750	3.47	1.59	1-3/8"		
	BW16-16MP	1"	1"-11 1/2	1.000		1.59	1-3/8"		
	BW16-20MP	1"	1-1/4"-11 1/2	1.000	3.80	1.68	1-11/16"		
	BW20-20MP	1-1/4"	1-1/4"-11 1/2	1.250	4.24	1.70	1-3/4"		
	BW20-24MP	1-1/4"	1-1/2"-11 1/2	1.250	4.33	1.79	2"		
	BW24-24MP	1-1/2"	1-1/2"-11 1/2	1.500	4.58	1.98	2-1/4"		
	BW32-32MP	2"	2"-11 1/2	2.000	5.39	2.13	2-5/8"		

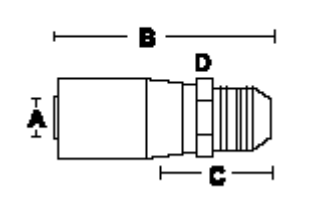

MALE BOSS O-RING RIGID	PART NUMBER			BARB A	O.A.L B	CUT OFF C			DROP F
		HOSE I.D.	THREAD				D	E	
	BW06-06MB	3/8"	9/16"-18	0.375	2.25	0.87	11/16"		
	BW08-08MB	1/2"	3/4"-16	0.500	2.36	1.01	7/8"		
	BW12-12MB	3/4"	1-1/16"-12	0.750	3.12	1.23	1-1/8"		
	BW12-16MB	3/4"	1-5/16"-12	0.750	3.20	1.25	1-3/8"		
	BW16-16MB	1"	1-5/16"-12	1.000	3.36	1.25	1-3/8"		
	BW16-20MB	1"	1-5/8"-12	1.000	3.37	1.26	1-7/8"		
	BW20-20MB	1-1/4"	1-5/8"-12	1.250	3.77	1.28	1-7/8"		
	BW20-24MB	1-1/4"	1-7/8"-12	1.250	4.10	1.61	2-1/4"		
	BW24-24MB	1-1/2"	1-7/8"-12	1.500	4.20	1.61	2-1/4"		
	BW32-32MB	2"	2-1/2"-12	2.000	5.12	1.82	2-5/8"		

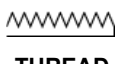

37° JIC MALE RIGID	PART NUMBER			BARB A	O.A.L B	CUT OFF C			DROP F
		HOSE I.D.	THREAD				D	E	
	BW06-06MJ	3/8"	9/16"-18	0.375	2.33	0.95	5/8"		
	BW08-08MJ	1/2"	3/4"-16	0.500	2.49	1.15	13/16"		
	BW08-10MJ	1/2"	7/8"-14	0.500	2.49	1.15	1"		
	BW12-12MJ	3/4"	1-1/16"-12	0.750	3.32	1.45	1-1/8"		
	BW12-16MJ	3/4"	1-5/16"-12	0.750	3.43	1.55	1-3/8"		
	BW16-16MJ	1"	1-5/16"-12	1.000	3.67	1.55	1-3/8"		
	BW16-20MJ	1"	1-5/8"-12	1.000	3.79	1.66	1-7/8"		
	BW20-20MJ	1-1/4"	1-5/8"-12	1.250	4.24	1.70	1-7/8"		
	BW20-24MJ	1-1/4"	1-7/8"-12	1.250	4.61	2.11	2-1/4"		
	BW24-24MJ	1-1/2"	1-7/8"-12	1.500	4.71	2.11	2-1/4"		
	BW32-32MJ	2"	2-1/2"-12	2.000	5.62	2.38	2-5/8"		

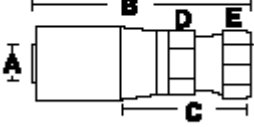
NATIONAL HOSE

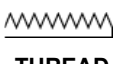
"BW" SERIES CRIMP COUPLINGS FOR BRAIDED & SPIRAL HYDRAULIC HOSES

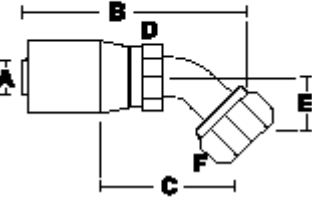

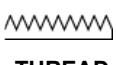
37° JIC FEMALE SWIVEL	PART NUMBER			BARB A	O.A.L B	CUT OFF C			DROP F
		HOSE I.D.	THREAD				D	E	
	BW06-06FJX	3/8"	9/16"-18	0.375	2.50	1.12	3/4"	11/16"	
	BW06-08FJX	3/8"	3/4"-16	0.375	2.53	1.16	3/4"	7/8"	
	BW08-08FJX	1/2"	3/4"-16	0.500	2.57	1.22	7/8"	7/8"	
	BW08-10FJX	1/2"	7/8"-14	0.500	2.71	1.36	7/8"	1"	
	BW10-10FJX	5/8"	7/8"-14	0.625	2.75	1.38	1"	1"	
	BW10-12FJX	5/8"	1-1/16"-12	0.625	2.75	1.38	1"	1-1/16"	
	BW12-12FJX	3/4"	1-1/16"-12	0.750	3.46	1.58	1-1/4"	1-1/16"	
	BW12-14FJX	3/4"	1-3/16"-12	0.750	3.45	1.56	1-1/4"	1-1/4"	
	BW12-16FJX	3/4"	1-5/16"-12	0.750	3.53	1.65	1-1/2"	1-3/8"	
	BW16-12FJX	1"	1-1/16"-12	1.000	3.71	1.59	1-1/2"	1-1/16"	
	BW16-16FJX	1"	1-5/16"-12	1.000	3.83	1.71	1-1/2"	1-3/8"	
	BW16-20FJX	1"	1-5/8"-12	1.000	4.00	1.71	2"	1-3/4"	
	BW20-20FJX	1-1/4"	1-5/8"-12	1.250	4.43	1.89	2"	1-3/4"	
	BW20-24FJX	1-1/4"	1-7/8"-12	1.250	4.67	2.17	2-1/4"	2-1/4"	
	BW24-24FJX	1-1/2"	1-7/8"-12	1.500	4.77	2.17	2-1/4"	2-1/4"	
	BW32-32FJX	2"	2-1/2"-12	2.000	5.95	2.70	2"	2"	

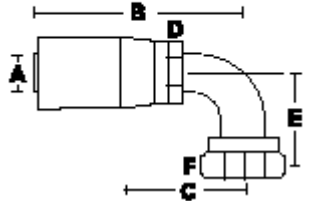

37° JIC FEMALE 45° SWIVEL	PART NUMBER			BARB A	O.A.L B	CUT OFF C		DROP E	
		HOSE I.D.	THREAD				D		F
	BW06-06FJX45	3/8"	9/16"-18	0.375	3.08	1.71		0.39	11/16"
	BW06-08FJX45	3/8"	3/4"-16	0.375	3.31	1.96		0.55	7/8"
	BW08-08FJX45	1/2"	3/4"-16	0.500	3.31	1.96		0.55	7/8"
	BW08-10FJX45	1/2"	7/8"-14	0.500	3.48	2.14		0.63	1"
	BW12-12FJX45	3/4"	1-1/16"-12	0.750	4.94	3.06		1.15	1-1/4"
	BW12-16FJX45	3/4"	1-5/16"-12	0.750	5.01	3.13		1.23	1-1/2"
	BW16-16FJX45	1"	1-5/16"-12	1.000	5.24	3.12		1.27	1-1/2"
	BW16-20FJX45	1"	1-5/8"-12	1.000	5.27	3.15		1.30	2"
	BW20-20FJX45	1-1/4"	1-5/8"-12	1.250	6.53	3.99		1.47	2"
	BW20-24FJX45	1-1/4"	1-7/8"-12	1.250	7.07	4.52		2.01	2-1/4"
	BW24-24FJX45	1-1/2"	1-7/8"-12	1.500	7.49	4.89		1.84	2-1/4"
	BW32-32FJX45	2"	2-1/2"-12	2.000	9.16	5.91		2.71	2-7/8"

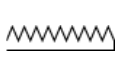

37° JIC FEMALE 90° SWIVEL	PART NUMBER			BARB A	O.A.L B	CUT OFF C		DROP E	
		HOSE I.D.	THREAD				D		F
	BW06-06FJX90	3/8"	9/16"-18	0.375	2.96	1.58		0.90	13/16"
	BW08-08FJX90	1/2"	3/4"-16	0.500	3.14	1.80		1.09	7/8"
	BW08-10FJX90	1/2"	7/8"-14	0.500	3.24	1.89		1.23	1"
	BW12-12FJX90	3/4"	1-1/16"-12	0.750	4.61	2.73		2.57	1-1/4"
	BW12-16FJX90	3/4"	1-5/16"-12	0.750	4.82	2.94		2.92	1-1/2"
	BW16-16FJX90	1"	1-5/16"-12	1.000	5.20	3.05		2.80	1-1/2"
	BW16-20FJX90	1"	1-5/8"-12	1.000	5.20	3.05		2.80	2"
	BW20-20FJX90	1-1/4"	1-5/8"-12	1.250	6.44	3.90		3.24	2"
	BW20-24FJX90	1-1/4"	1-7/8"-12	1.250	6.45	3.90		3.24	2-1/4"
	BW24-24FJX90	1-1/2"	1-7/8"-12	1.500	6.74	4.14		3.94	2-1/4"
	BW32-32FJX90	2"	2-1/2"-12	2.000	8.25	5.00		5.60	2-7/8"

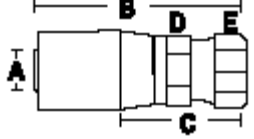
NATIONAL HOSE

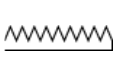
"BW" SERIES CRIMP COUPLINGS FOR BRAIDED & SPIRAL HYDRAULIC HOSES

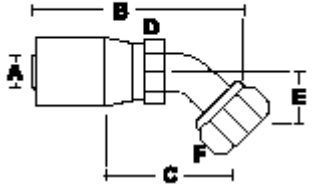

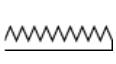
O-RING FACE SEAL FEMALE SWIVEL	PART NUMBER			BARB A	O.A.L B	CUT OFF C			DROP F
		HOSE I.D.	THREAD				D	E	
	BW06-06FFX	3/8"	11/16"-16	0.375	2.50	1.13	11/16"	11/16"	
	BW08-08FFX	1/2"	13/16"-16	0.500	2.61	1.26	7/8"	7/8"	
	BW08-10FFX	1/2"	1"-14	0.500	2.77	1.42	7/8"	1"	
	BW10-10FFX	5/8"	1"-14	0.625	2.77	1.42	1"	1"	
	BW12-12FFX	3/4"	1-3/16"-12	0.750	3.51	1.63	1-1/8"	1-3/8"	
	BW12-16FFX	3/4"	1-7/16"-12	0.750	3.66	1.78	1-3/8"	1-5/8"	
	BW16-16FFX	1"	1-7/16"-12	1.000	3.90	1.78	1-3/8"	1-5/8"	
	BW16-20FFX	1"	1-11/16"-12	1.000	3.90	1.78	1-5/8"	1-7/8"	
	BW20-20FFX	1-1/4"	1-11/16"-12	1.250	4.33	1.78	1-3/4"	1-7/8"	
	BW20-24FFX	1-1/4"	2"-12	1.250	4.33	1.79	1-3/4"	1-7/8"	
	BW24-24FFX	1-1/2"	2"-12	1.500	4.79	2.19	2-1/4"	2-3/8"	

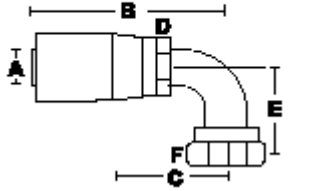

O-RING FACE SEAL 45° FEMALE SWIVEL	PART NUMBER			BARB A	O.A.L B	CUT OFF C		DROP E	
		HOSE I.D.	THREAD				D		F
	BW06-06FFX45	3/8"	11/16"-16	0.375	2.93	1.55		0.43	11/16"
	BW08-08FFX45	1/2"	13/16"-16	0.500	3.14	1.80		0.59	7/8"
	BW08-10FFX45	1/2"	1"-14	0.500	3.62	2.28		0.65	1"
	BW10-10FFX45	5/8"	1"-14	0.625	3.62	2.28		0.65	1"
	BW12-12FFX45	3/4"	1-3/16"-12	0.750	4.62	2.57		0.83	1-3/8"
	BW12-16FFX45	3/4"	1-7/16"-12	0.750	4.73	2.57		0.94	1-5/8"
	BW16-16FFX45	1"	1-7/16"-12	1.000	5.12	2.57		0.94	1-5/8"
	BW16-20FFX45	1"	1-11/16"-12	1.000	6.20	2.94		0.96	1-7/8"
	BW20-20FFX45	1-1/4"	1-11/16"-12	1.250	6.23	3.71		1.00	1-7/8"
	BW20-24FFX45	1-1/4"	2"-12	1.250	6.23	4.12		1.07	1-7/8"
	BW24-24FFX45	1-1/2"	2"-12	1.500	6.62	4.12		1.07	2-3/8"

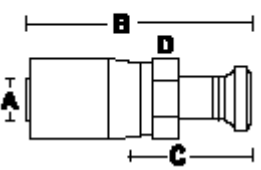

O-RING FACE SEAL 90° FEMALE SWIVEL	PART NUMBER			BARB A	O.A.L B	CUT OFF C		DROP E	
		HOSE I.D.	THREAD				D		F
	BW06-06FFX90	3/8"	11/16"-16	0.375	2.92	1.55		0.90	11/16"
	BW08-08FFX90	1/2"	13/16"-16	0.500	3.14	1.80		1.15	7/8"
	BW08-10FFX90	1/2"	1"-14	0.500	3.65	2.30		1.15	1"
	BW10-10FFX90	5/8"	1"-14	0.625	3.65	2.30		1.15	1"
	BW12-12FFX90	3/4"	1-3/16"-12	0.750	4.45	2.57		1.88	1-3/8"
	BW12-16FFX90	3/4"	1-7/16"-12	0.750	4.45	2.57		2.21	1-5/8"
	BW16-16FFX90	1"	1-7/16"-12	1.000	5.06	2.57		2.21	1-5/8"
	BW16-20FFX90	1"	1-11/16"-12	1.000	5.10	2.94		2.51	1-7/8"
	BW20-20FFX90	1-1/4"	1-11/16"-12	1.250	6.25	3.71		2.51	1-7/8"
	BW20-24FFX90	1-1/4"	2"-12	1.250	6.70	4.12		2.70	1-7/8"
	BW24-24FFX90	1-1/2"	2"-12	1.500	6.72	4.12		2.70	2-3/8"

NATIONAL HOSE

"BW" SERIES CRIMP COUPLINGS FOR BRAIDED & SPIRAL HYDRAULIC HOSES

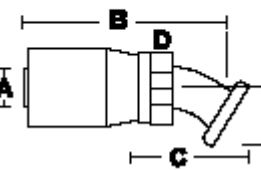
CODE 61 FLANGE RIGID	PART NUMBER			BARB A	O.A.L B	CUT OFF C	DROP E	FLANGE O.D. (inch)	FLANGE THICKNESS
		HOSE I.D.	FLANGE						
	BW12-12C61	3/4"	3/4"	0.750		2.30		1.50	0.265
	BW12-16C61	3/4"	1"	0.750	4.22	2.34		1.75	0.315
	BW16-16C61	1"	1"	1.000	4.45	2.35		1.75	0.315
	BW16-20C61	1"	1-1/4"	1.000	4.45	2.35		2.00	0.315
	BW20-20C61	1-1/4"	1-1/4"	1.250	5.30	2.75		2.00	0.315
	BW20-24C61	1-1/4"	1-1/2"	1.250	5.36	2.82		2.38	0.315
	BW24-24C61	1-1/2"	1-1/2"	1.500	5.51	2.91		2.38	0.315
	BW24-32C61	1-1/2"	2"	1.500	5.43	2.85		2.81	0.375
	BW32-32C61	2"	2"	2.000	7.30	4.05		2.81	0.375
	BW32-40C61	2"	2-1/2"	2.000	7.30	4.05		3.31	0.375

CODE 61 FLANGE 22° RIGID	PART NUMBER			BARB A	O.A.L B	CUT OFF C	DROP E	FLANGE O.D. (inch)	FLANGE THICKNESS
		HOSE I.D.	FLANGE						
	BW12-12C61-22	3/4"	3/4"	0.750	4.59	2.71	0.49	1.50	0.265
	BW12-16C61-22	3/4"	1"	0.750	4.59	2.71	0.49	1.75	0.315
	BW16-16C61-22	1"	1"	1.000	4.95	2.83	0.50	1.75	0.315
	BW16-20C61-22	1"	1-1/4"	1.000	4.95	2.83	0.50	2.00	0.315
	BW20-20C61-22	1-1/4"	1-1/4"	1.250	5.61	3.07	0.48	2.00	0.315
	BW20-24C61-22	1-1/4"	1-1/2"	1.250	5.70	3.16	0.50	2.38	0.315
	BW24-24C61-22	1-1/2"	1-1/2"	1.500	6.60	4.01	0.67	2.38	0.315
	BW32-32C61-22	2"	2"	2.000	8.11	4.88	0.97	2.81	0.375

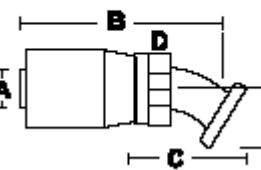
CODE 61 FLANGE 30° RIGID	PART NUMBER			BARB A	O.A.L B	CUT OFF C	DROP E	FLANGE O.D. (inch)	FLANGE THICKNESS
		HOSE I.D.	FLANGE						
	BW12-12C61-30	3/4"	3/4"	0.750	4.68	0.51	0.67	1.50	0.265
	BW12-16C61-30	3/4"	1"	0.750	4.68	0.51	0.67	1.75	0.315
	BW16-16C61-30	1"	1"	1.000	4.93	0.76	0.60	1.75	0.315
	BW16-20C61-30	1"	1-1/4"	1.000	4.93	0.76	0.60	2.00	0.315
	BW20-20C61-30	1-1/4"	1-1/4"	1.250	5.87	1.01	0.72	2.00	0.315
	BW20-24C61-30	1-1/4"	1-1/2"	1.250	5.92	1.01	0.75	2.38	0.315
	BW24-24C61-30	1-1/2"	1-1/2"	1.500	6.93	1.18	0.84	2.38	0.315
	BW32-32C61-30	2"	2"	2.000	8.45	1.69	1.43	2.81	0.375

NATIONAL HOSE

"BW" SERIES CRIMP COUPLINGS FOR BRAIDED & SPIRAL HYDRAULIC HOSES



CODE 61 FLANGE 45° RIGID				BARB	O.A.L	CUT OFF	DROP	FLANGE	FLANGE
		HOSE I.D.	FLANGE	A	B	C	E	O.D. (inch)	THICKNESS
	PART NUMBER	BW12-12C61-45	3/4"	0.750	4.65	2.77	0.86	1.50	0.265
	BW12-16C61-45	3/4"	1"	0.750	4.65	2.77	0.86	1.75	0.315
	BW16-16C61-45	1"	1"	1.000	4.83	2.71	1.13	1.75	0.315
	BW16-20C61-45	1"	1-1/4"	1.000	4.92	2.80	0.95	2.00	0.315
	BW20-20C61-45	1-1/4"	1-1/4"	1.250	6.18	3.65	1.17	2.00	0.315
	BW20-24C61-45	1-1/4"	1-1/2"	1.250	6.23	3.67	1.21	2.38	0.315
	BW24-24C61-45	1-1/2"	1-1/2"	1.500	7.04	4.45	1.41	2.38	0.315
	BW32-32C61-45	2"	2"	2.000	8.70	5.45	2.26	2.81	0.375



CODE 61 FLANGE 60° RIGID				BARB	O.A.L	CUT OFF	DROP	FLANGE	FLANGE
		HOSE I.D.	FLANGE	A	B	C	E	O.D. (inch)	THICKNESS
	PART NUMBER	BW12-12C61-60	3/4"	0.750	4.79	2.91	0.86	1.50	0.265
	BW12-16C61-60	3/4"	1"	0.750	4.79	2.91	0.86	1.75	0.315
	BW16-16C61-60	1"	1"	1.000	5.62	3.50	1.13	1.75	0.315
	BW16-20C61-60	1"	1-1/4"	1.000	5.60	3.49	0.95	2.00	0.315
	BW20-20C61-60	1-1/4"	1-1/4"	1.250	6.66	4.11	1.17	2.00	0.315
	BW20-24C61-60	1-1/4"	1-1/2"	1.250	6.60	4.05	1.21	2.38	0.315
	BW24-24C61-60	1-1/2"	1-1/2"	1.500	7.42	4.82	1.40	2.38	0.315
	BW32-32C61-60	2"	2"	2.000	8.75	5.50	2.26	2.81	0.375

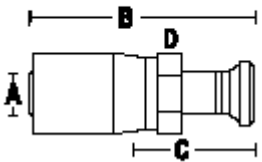

CODE 61 FLANGE 90° RIGID				BARB	O.A.L	CUT OFF	DROP	FLANGE	FLANGE
		HOSE I.D.	FLANGE	A	B	C	E	O.D. (inch)	THICKNESS
	PART NUMBER	BW12-12C61-90	3/4"	0.750	4.82	2.94	2.40	1.50	0.265
	BW12-16C61-90	3/4"	1"	0.750	4.83	2.95	2.42	1.75	0.315
	BW16-16C61-90	1"	1"	1.000	5.20	3.08	2.80	1.75	0.315
	BW16-20C61-90	1"	1-1/4"	1.000	4.92	2.80	2.24	2.00	0.315
	BW20-20C61-90	1-1/4"	1-1/4"	1.250	6.47	3.93	2.68	2.00	0.315
	BW20-24C61-90	1-1/4"	1-1/2"	1.250	6.47	3.93	2.74	2.38	0.315
	BW24-24C61-90	1-1/2"	1-1/2"	1.500	6.74	4.14	3.31	2.38	0.315
	BW32-32C61-90	2"	2"	2.000	8.25	5.00	1.94	2.81	0.375

NATIONAL HOSE

"BW" SERIES CRIMP COUPLINGS FOR BRAIDED & SPIRAL HYDRAULIC HOSES

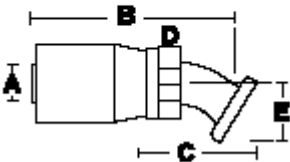
CODE 62 FLANGE RIGID				BARB A	O.A.L B	CUT OFF C	DROP E	FLANGE O.D. (inch)	FLANGE THICKNESS
	PART NUMBER	HOSE I.D.	FLANGE						
	BW12-12C62	3/4"	3/4"	0.750	4.21	2.30		1.63	0.345
	BW12-16C62	3/4"	1"	0.750	4.22	2.34		1.88	0.375
	BW16-16C62	1"	1"	1.000	4.45	2.35		1.88	0.375
	BW16-20C62	1"	1-1/4"	1.000	4.45	2.35		2.13	0.405
	BW20-20C62	1-1/4"	1-1/4"	1.250	5.30	2.75		2.13	0.405
	BW20-24C62	1-1/4"	1-1/2"	1.250	5.36	2.82		2.50	0.495
	BW24-24C62	1-1/2"	1-1/2"	1.500	5.51	2.91		2.50	0.495
BW32-32C62	2"	2"	2.000	7.30	4.05		3.13	0.495	

CODE 62 FLANGE 22° RIGID				BARB A	O.A.L B	CUT OFF C	DROP E	FLANGE O.D. (inch)	FLANGE THICKNESS
	PART NUMBER	HOSE I.D.	FLANGE						
	BW12-12C62-22	3/4"	3/4"	0.750	4.59	2.71	0.49	1.63	0.345
	BW12-16C62-22	3/4"	1"	0.750	4.59	2.71	0.49	1.88	0.375
	BW16-16C62-22	1"	1"	1.000	4.95	2.83	0.50	1.88	0.375
	BW16-20C62-22	1"	1-1/4"	1.000	4.95	2.83	0.50	2.13	0.405
	BW20-20C62-22	1-1/4"	1-1/4"	1.250	5.61	3.07	0.48	2.13	0.405
	BW20-24C62-22	1-1/4"	1-1/2"	1.250	5.70	3.16	0.50	2.50	0.495
	BW24-24C62-22	1-1/2"	1-1/2"	1.500	6.60	4.01	0.67	2.50	0.495
BW32-32C62-22	2"	2"	2.000	8.11	4.88	0.97	3.13	0.495	

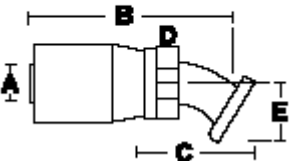
CODE 62 FLANGE 30° RIGID				BARB A	O.A.L B	CUT OFF C	DROP E	FLANGE O.D. (inch)	FLANGE THICKNESS
	PART NUMBER	HOSE I.D.	FLANGE						
	BW12-12C62-30	3/4"	3/4"	0.750	4.68	0.51	0.67	1.63	0.345
	BW12-16C62-30	3/4"	1"	0.750	4.68	0.51	0.67	1.88	0.375
	BW16-16C62-30	1"	1"	1.000	4.93	0.76	0.60	1.88	0.375
	BW16-20C62-30	1"	1-1/4"	1.000	4.93	0.76	0.60	2.13	0.405
	BW20-20C62-30	1-1/4"	1-1/4"	1.250	5.87	1.01	0.72	2.13	0.405
	BW20-24C62-30	1-1/4"	1-1/2"	1.250	5.92	1.01	0.75	2.50	0.495
	BW24-24C62-30	1-1/2"	1-1/2"	1.500	6.93	1.18	0.84	2.50	0.495
BW32-32C62-30	2"	2"	2.000	8.45	1.67	1.43	3.13	0.495	

NATIONAL HOSE

"BW" SERIES CRIMP COUPLINGS FOR BRAIDED & SPIRAL HYDRAULIC HOSES

CODE 62 FLANGE 45° RIGID		HOSE I.D.	FLANGE	BARB A	O.A.L B	CUT OFF C	DROP E	FLANGE O.D. (inch)	FLANGE THICKNESS
	PART NUMBER	HOSE I.D.	FLANGE	BARB A	O.A.L B	CUT OFF C	DROP E	FLANGE O.D. (inch)	FLANGE THICKNESS
	BW12-12C62-45	3/4"	3/4"	0.750	4.65	2.77	0.86	1.63	0.345
	BW12-16C62-45	3/4"	1"	0.750	4.65	2.77	0.86	1.88	0.375
	BW16-16C62-45	1"	1"	1.000	4.83	2.71	1.13	1.88	0.375
	BW16-20C62-45	1"	1-1/4"	1.000	4.92	2.80	0.95	2.13	0.405
	BW20-20C62-45	1-1/4"	1-1/4"	1.250	6.18	3.65	1.17	2.13	0.405
	BW20-24C62-45	1-1/4"	1-1/2"	1.250	6.23	3.67	1.21	2.50	0.495
	BW24-24C62-45	1-1/2"	1-1/2"	1.500	7.04	4.45	1.40	2.50	0.495
BW32-32C62-45	2"	2"	2.000	8.70	5.45	2.26	3.13	0.495	

CODE 62 FLANGE 90° RIGID		HOSE I.D.	FLANGE	BARB A	O.A.L B	CUT OFF C	DROP E	FLANGE O.D. (inch)	FLANGE THICKNESS
	PART NUMBER	HOSE I.D.	FLANGE	BARB A	O.A.L B	CUT OFF C	DROP E	FLANGE O.D. (inch)	FLANGE THICKNESS
	BW12-12C62-90	3/4"	3/4"	0.750	4.82	2.94	2.40	1.63	0.345
	BW12-16C62-90	3/4"	1"	0.750	4.83	2.95	2.42	1.88	0.375
	BW16-16C62-90	1"	1"	1.000	5.20	3.08	2.80	1.88	0.375
	BW16-20C62-90	1"	1-1/4"	1.000	4.92	2.80	2.24	2.13	0.405
	BW20-20C62-90	1-1/4"	1-1/4"	1.250	6.47	3.93	2.68	2.13	0.405
	BW20-24C62-90	1-1/4"	1-1/2"	1.250	6.47	3.93	2.74	2.50	0.495
	BW24-24C62-90	1-1/2"	1-1/2"	1.500	6.74	4.14	3.31	2.50	0.495
BW32-32C62-90	2"	2"	2.000	8.25	5.00	1.94	3.13	0.495	

JIS 30 SEAT FEMALE SWIVEL		HOSE I.D.	THREAD	BARB A	O.A.L B	CUT OFF C	D	E	DROP F
	PART NUMBER	HOSE I.D.	THREAD	BARB A	O.A.L B	CUT OFF C	D	E	DROP F
	BW06-06JISX	3/8"	3/8"-19	0.375		1.71			
	BW08-08JISX	1/2"	1/2"-14	0.500		1.45			
	BW12-12JISX	3/4"	3/4"-14	0.750		1.61			
BW16-16JISX	1"	1"-11	1.000		1.81				



KOMATSU JIS 30 SEAT FEMALE SWIVEL		HOSE I.D.	THREAD	BARB A	O.A.L B	CUT OFF C	D	E	DROP F
	PART NUMBER	HOSE I.D.	THREAD	BARB A	O.A.L B	CUT OFF C	D	E	DROP F
	BW06-06KOMX	3/8"	M18 X 1.5	0.375		1.18			
	BW08-08KOMX	1/2"	M22 X 1.5	0.500		1.50			
	BW10-10KOMX	5/8"	M24 X 1.5	0.625		1.63			
	BW12-12KOMX	3/4"	M30 X 1.5	0.750		1.76			
	BW16-16KOMX	1"	M33 X 1.5	1.000		1.81			
BW20-20KOMX	1-1/4"	M36 X 1.5	1.250		2.28				
BW24-24KOMX	1-1/2"	M42 X 1.5	1.500		2.46				

NATIONAL HOSE

"BW" SERIES CRIMP COUPLINGS FOR BRAIDED & SPIRAL HYDRAULIC HOSES

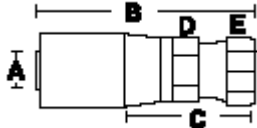

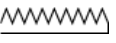
**BRITISH STANDARD PIPE
60 CONE FEMALE SWIVEL**



PART NUMBER			BARB A	O.A.L B	CUT OFF C			DROP F
	HOSE I.D.	THREAD				D	E	
BW06-06BSPX	3/8"	3/8"-19	0.375		1.21			
BW08-08BSPX	1/2"	1/2"-14	0.500		1.45			
BW12-12BSPX	3/4"	3/4"-14	0.750		1.56			
BW16-16BSPX	1"	1"-11	1.000		1.61			
BW20-20BSPX	1-1/4"	1-1/4"-11	1.250		1.85			

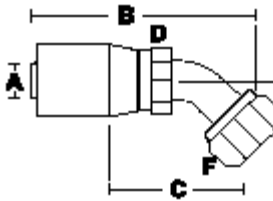

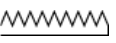
**BRITISH STANDARD PIPE 60
CONE 45 TUBE FEMALE SWIVEL**



PART NUMBER			BARB A	O.A.L B	CUT OFF C		DROP E	
	HOSE I.D.	THREAD				D		F
BW06-06BSPX45	3/8"	3/8"-19	0.375		2.16		0.91	
BW08-08BSPX45	1/2"	1/2"-14	0.500		2.42		1.00	
BW12-12BSPX45	3/4"	3/4"-14	0.750		3.16		1.25	
BW16-16BSPX45	1"	1"-11	1.000		3.31		1.50	

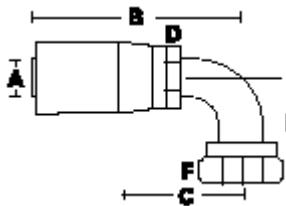

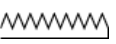

**BRITISH STANDARD PIPE 60
CONE 90 TUBE FEMALE SWIVEL**





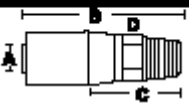



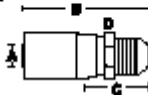

PART NUMBER			BARB A	O.A.L B	CUT OFF C		DROP E	
	HOSE I.D.	THREAD				D		F
BW06-06BSPX90	3/8"	3/8"-19	0.375		1.54		1.66	
BW08-08BSPX90	1/2"	1/2"-14	0.500		1.80		1.95	
BW12-12BSPX90	3/4"	3/4"-14	0.750		2.57		2.38	
BW16-16BSPX90	1"	1"-11	1.000		2.70		2.99	



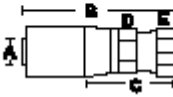

NATIONAL HOSE



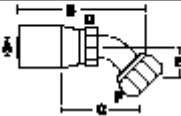

“JJ” SERIES (SKIVE TYPE) CRIMP COUPLINGS FOR SPIRAL HYDRAULIC HOSES



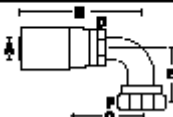

MALE PIPE NPTF RIGID 	PART NUMBER	 HOSE I.D.	 THREAD	BARB A	O.A.L B	CUT OFF C	 D	 E	DROP F
	JJ20-20MP	1-1/4"	1-1/4"-11 1/2	1.250	4.82	2.41	2"		
JJ24-24MP	1-1/2"	1-1/2"-11 1/2	1.500	4.98	1.98	2-1/8"			
JJ32-32MP	2"	2"-11 1/2	2.000	6.42	2.13	2-5/8"			



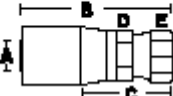

37° JIC MALE RIGID 	PART NUMBER	 HOSE I.D.	 THREAD	BARB A	O.A.L B	CUT OFF C	 D	 E	DROP F
	JJ20-20MJ	1-1/4"	1-5/8"-12	1.250		2.41	2"		
JJ24-24MJ	1-1/2"	1-7/8"-12	1.500	5.06	2.53	2-1/8"			
JJ32-32MJ	2"	2-1/2"-12	2.000	6.72	3.13	2-5/8"			



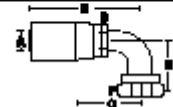

37° JIC FEMALE SWIVEL 	PART NUMBER	 HOSE I.D.	 THREAD	BARB A	O.A.L B	CUT OFF C	 D	 E	DROP F
	JJ20-20FJX	1-1/4"	1-5/8"-12	1.250	4.94	2.53	2"	2"	
JJ24-24FJX	1-1/2"	1-7/8"-12	1.500	5.38	2.17	2-1/4"	2-1/4"		
JJ32-32FJX	2"	2-1/2"-12	2.000	6.92	2.70	2-7/8"	2-5/8"		

37° JIC FEMALE 45° SWIVEL 	PART NUMBER	 HOSE I.D.	 THREAD	BARB A	O.A.L B	CUT OFF C	 D	DROP E	 F
	JJ20-20FJX45	1-1/4"	1-5/8"-12	1.250	5.52	3.28			1.38
JJ24-24FJX45	1-1/2"	1-7/8"-12	1.500	6.92	4.89			1.84	2-1/4"
JJ32-32FJX45	2"	2-1/2"-12	2.000	8.46	5.91			2.71	2-7/8"

37° JIC FEMALE 90° SWIVEL 	PART NUMBER	 HOSE I.D.	 THREAD	BARB A	O.A.L B	CUT OFF C	 D	DROP E	 F
	JJ20-20FJX90	1-1/4"	1-5/8"-12	1.250	6.64	4.23			1.38
JJ24-24FJX90	1-1/2"	1-7/8"-12	1.500	6.31	4.14			3.94	2-1/4"
JJ32-32FJX90	2"	2-1/2"-12	2.000	7.45	5.00			5.60	2-7/8"

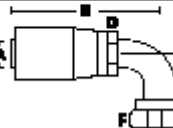

O-RING FACE SEAL FEMALE SWIVEL 	PART NUMBER	 HOSE I.D.	 THREAD	BARB A	O.A.L B	CUT OFF C	 D	 E	DROP F
	JJ20-20FFX	1-1/4"	1-11/16"-12	1.250	4.40	2.00	1-13/16"	1-7/8"	
JJ24-24FFX	1-1/2"	2"-12	1.500	4.84	2.19	2-1/4"	2-3/8"		



O-RING FACE SEAL 45° FEMALE SWIVEL 	PART NUMBER	 HOSE I.D.	 THREAD	BARB A	O.A.L B	CUT OFF C	 D	DROP E	 F
	JJ20-20FFX45	1-1/4"	1-11/16"-12	1.250	5.99	3.59			1.34
JJ24-24FFX45	1-1/2"	2"-12	1.500	6.87	4.89			1.84	2-1/4"



O-RING FACE SEAL 90° FEMALE SWIVEL 	PART NUMBER	 HOSE I.D.	 THREAD	BARB A	O.A.L B	CUT OFF C	 D	DROP E	 F
	JJ20-20FFX90	1-1/4"	1-11/16"-12	1.250	5.65	3.25			3.92
JJ24-24FFX90	1-1/2"	2"-12	1.500	6.31	4.14			3.94	2-1/4"

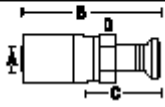

NATIONAL HOSE

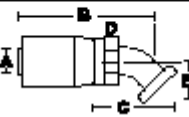

“JJ” SERIES (SKIVE TYPE) CRIMP COUPLINGS FOR SPIRAL HYDRAULIC HOSES

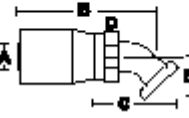
CODE 61 FLANGE RIGID	PART NUMBER	 HOSE I.D.	 FLANGE	BARB A	O.A.L B	CUT OFF C	DROP E	FLANGE O.D. (inch)	FLANGE THICKNESS
	JJ20-20C61	1-1/4"	1-1/4"	1.250	5.39	2.97		2.00	0.315
	JJ20-24C61	1-1/4"	1-1/2"	1.250	5.76	3.34		2.38	0.315
	JJ24-24C61	1-1/2"	1-1/2"	1.500	6.09	2.91		2.38	0.315
	JJ24-32C61	1-1/2"	2"	1.500	6.91	2.91		2.81	0.375
	JJ32-32C61	2"	2"	2.000	8.08	4.05		2.81	0.375

CODE 61 FLANGE 22° BEND RIGID	PART NUMBER	 HOSE I.D.	 FLANGE	BARB A	O.A.L B	CUT OFF C	DROP E	FLANGE O.D. (inch)	FLANGE THICKNESS
	JJ20-20C61-22	1-1/4"	1-1/4"	1.250	5.54	3.13	0.53	2.00	0.315
	JJ20-24C61-22	1-1/4"	1-1/2"	1.250	5.60	3.38	0.56	2.38	0.315
	JJ24-24C61-22	1-1/2"	1-1/2"	1.500	6.40	4.01	0.67	2.38	0.315
	JJ24-32C61-22	1-1/2"	2"	1.500	6.52	4.00	0.74	2.81	0.375
	JJ32-32C61-22	2"	2"	2.000	8.68	4.88	0.97	2.81	0.375

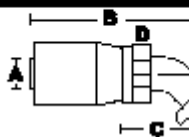

CODE 61 FLANGE 30° BEND RIGID	PART NUMBER	 HOSE I.D.	 FLANGE	BARB A	O.A.L B	CUT OFF C	DROP E	FLANGE O.D. (inch)	FLANGE THICKNESS
	JJ20-20C61-30	1-1/4"	1-1/4"	1.250	5.76	3.36	0.78	2.00	0.315
	JJ20-24C61-30	1-1/4"	1-1/2"	1.250	5.81	3.41	0.81	2.38	0.315
	JJ24-24C61-30	1-1/2"	1-1/2"	1.500	6.59	4.06	0.98	2.38	0.315
	JJ24-32C61-30	1-1/2"	2"	1.500	6.70	4.17	1.05	2.81	0.375
	JJ32-32C61-30	2"	2"	2.000	8.92	5.34	1.33	2.81	0.375

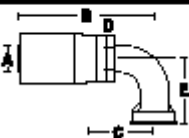

CODE 61 FLANGE 45° BEND RIGID	PART NUMBER	 HOSE I.D.	 FLANGE	BARB A	O.A.L B	CUT OFF C	DROP E	FLANGE O.D. (inch)	FLANGE THICKNESS
	JJ20-20C61-45	1-1/4"	1-1/4"	1.250	5.92	3.50	1.27	2.00	0.315
	JJ20-24C61-45	1-1/4"	1-1/2"	1.250	5.96	3.56	1.32	2.38	0.315
	JJ24-24C61-45	1-1/2"	1-1/2"	1.500	6.72	4.19	1.58	2.38	0.315
	JJ24-32C61-45	1-1/2"	2"	1.500	6.81	4.28	1.67	2.81	0.375
	JJ32-32C61-45	2"	2"	2.000	9.29	5.70	2.21	2.81	0.375



CODE 61 FLANGE 60° BEND RIGID	PART NUMBER	 HOSE I.D.	 FLANGE	BARB A	O.A.L B	CUT OFF C	DROP E	FLANGE O.D. (inch)	FLANGE THICKNESS
	JJ20-20C61-60	1-1/4"	1-1/4"	1.250	5.94	3.53	2.07	2.00	0.315
	JJ20-24C61-60	1-1/4"	1-1/2"	1.250	5.97	3.56	2.12	2.38	0.315
	JJ24-24C61-60	1-1/2"	1-1/2"	1.500	7.54	4.04	2.21	2.38	0.315
	JJ24-32C61-60	1-1/2"	2"	1.500	7.61	5.09	2.32	2.81	0.375
	JJ32-32C61-60	2"	2"	2.000	9.35	5.77	3.12	2.81	0.375

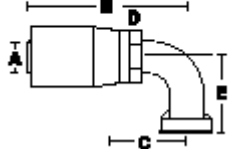

NATIONAL HOSE

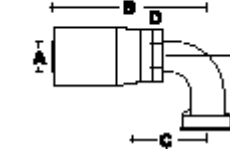

"JJ" SERIES (SKIVE TYPE) CRIMP COUPLINGS FOR SPIRAL HYDRAULIC HOSES

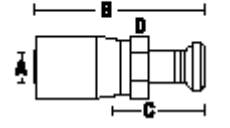
CODE 61 FLANGE 67° BEND RIGID	PART NUMBER			BARB A	O.A.L B	CUT OFF C	DROP E	FLANGE O.D. (inch)	FLANGE THICKNESS
		HOSE I.D.	FLANGE						
	JJ20-20C61-67	1-1/4"	1-1/4"	1.250	5.94	3.53	2.07	2.00	0.315
	JJ20-24C61-67	1-1/4"	1-1/2"	1.250	5.96	3.56	2.12	2.38	0.315
	JJ24-24C61-67	1-1/2"	1-1/2"	1.500	6.70	4.17	2.53	2.38	0.315
	JJ24-32C61-67	1-1/2"	2"	1.500	6.75	4.23	2.65	2.81	0.375
	JJ32-32C61-67	2"	2"	2.000	9.15	5.56	3.48	2.81	0.375

CODE 61 FLANGE 90° BEND RIGID	PART NUMBER			BARB A	O.A.L B	CUT OFF C	DROP E	FLANGE O.D. (inch)	FLANGE THICKNESS
		HOSE I.D.	FLANGE						
	JJ20-20C61-90	1-1/4"	1-1/4"	1.250	5.65	3.25	2.80	2.00	0.315
	JJ20-24C61-90	1-1/4"	1-1/2"	1.250	5.65	3.25	2.87	2.38	0.315
	JJ24-24C61-90	1-1/2"	1-1/2"	1.500	6.31	3.78	3.41	2.38	0.315
	JJ24-32C61-90	1-1/2"	2"	1.500	6.31	3.78	3.53	2.81	0.375
	JJ32-32C61-90	2"	2"	2.000	8.83	5.25	4.88	2.81	0.375

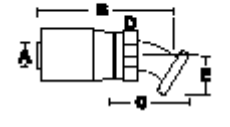

CODE 62 FLANGE RIGID	PART NUMBER			BARB A	O.A.L B	CUT OFF C	DROP E	FLANGE O.D. (inch)	FLANGE THICKNESS
		HOSE I.D.	FLANGE						
	JJ20-20C62	1-1/4"	1-1/4"	1.250	5.88	3.47		2.13	0.405
	JJ20-24C62	1-1/4"	1-1/2"	1.250	5.94	3.53		2.50	0.495
	JJ24-24C62	1-1/2"	1-1/2"	1.500	6.06	2.91		2.50	0.495
	JJ24-32C62	1-1/2"	2"	1.500	6.56	2.91		3.13	0.495
	JJ32-32C62	2"	2"	2.000	8.58	4.05		3.13	0.495

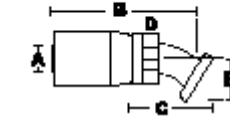

CODE 62 FLANGE 22° BEND RIGID	PART NUMBER			BARB A	O.A.L B	CUT OFF C	DROP E	FLANGE O.D. (inch)	FLANGE THICKNESS
		HOSE I.D.	FLANGE						
	JJ20-20C62-22	1-1/4"	1-1/4"	1.250	5.71	3.31	0.61	2.13	0.405
	JJ20-24C62-22	1-1/4"	1-1/2"	1.250	5.77	3.38	0.63	2.50	0.495
	JJ24-24C62-22	1-1/2"	1-1/2"	1.500	6.69	4.16	0.81	2.50	0.495
	JJ24-32C62-22	1-1/2"	2"	1.500	7.58	4.59	0.97	3.13	0.495
	JJ32-32C62-22	2"	2"	2.000	9.14	5.56	1.12	3.13	0.495

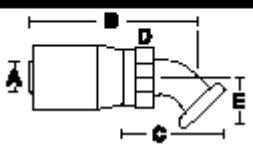

CODE 62 FLANGE 30° BEND RIGID	PART NUMBER			BARB A	O.A.L B	CUT OFF C	DROP E	FLANGE O.D. (inch)	FLANGE THICKNESS
		HOSE I.D.	FLANGE						
	JJ20-20C62-30	1-1/4"	1-1/4"	1.250	5.92	3.50	0.87	2.13	0.405
	JJ20-24C62-30	1-1/4"	1-1/2"	1.250	5.97	3.56	0.90	2.50	0.495
	JJ24-24C62-30	1-1/2"	1-1/2"	1.500	6.68	4.14	0.84	2.50	0.495
	JJ24-32C62-30	1-1/2"	2"	1.500	7.58	4.55	1.02	3.13	0.495
	JJ32-32C62-30	2"	2"	2.000	9.16	5.45	1.14	3.13	0.495

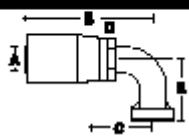

NATIONAL HOSE

"JJ" SERIES (SKIVE TYPE) CRIMP COUPLINGS FOR SPIRAL HYDRAULIC HOSES

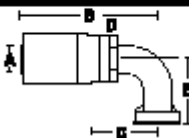
CODE 62 FLANGE 45° BEND RIGID 	PART NUMBER	 HOSE I.D.	 FLANGE	BARB A	O.A.L B	CUT OFF C	DROP E	FLANGE O.D. (inch)	FLANGE THICKNESS
	JJ20-20C62-45	1-1/4"	1-1/4"	1.250	6.05	3.66	1.40	2.13	0.405
JJ20-24C62-45	1-1/4"	1-1/2"	1.250	6.09	3.69	1.45	2.50	0.495	
JJ24-24C62-45	1-1/2"	1-1/2"	1.500	6.95	1.19	1.80	2.50	0.495	
JJ24-32C62-45	1-1/2"	2"	1.500	7.86	1.32	1.32	3.13	0.495	
JJ32-32C62-45	2"	2"	2.000	9.64	1.53	1.53	3.13	0.495	



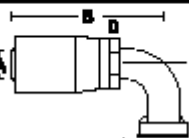

CODE 62 FLANGE 60° BEND RIGID 	PART NUMBER	 HOSE I.D.	 FLANGE	BARB A	O.A.L B	CUT OFF C	DROP E	FLANGE O.D. (inch)	FLANGE THICKNESS
	JJ20-20C62-60	1-1/4"	1-1/4"	1.250	6.03	3.50	1.95	2.13	0.405
JJ20-24C62-60	1-1/4"	1-1/2"	1.250	6.06	3.66	2.00	2.50	0.495	
JJ24-24C62-60	1-1/2"	1-1/2"	1.500	7.54	4.04	2.21	2.50	0.495	
JJ24-32C62-60	1-1/2"	2"	1.500	7.61	5.09	2.32	3.13	0.495	
JJ32-32C62-60	2"	2"	2.000	9.35	5.77	3.12	3.13	0.495	



CODE 62 FLANGE 67° BEND RIGID 	PART NUMBER	 HOSE I.D.	 FLANGE	BARB A	O.A.L B	CUT OFF C	DROP E	FLANGE O.D. (inch)	FLANGE THICKNESS
	JJ20-20C62-67	1-1/4"	1-1/4"	1.250	6.03	3.59	2.24	2.13	0.405
JJ24-24C62-67	1-1/2"	1-1/2"	1.500	6.70	4.17	2.53	2.50	0.495	
JJ24-32C62-67	1-1/2"	2"	1.500	6.75	4.23	2.65	3.13	0.495	
JJ32-32C62-67	2"	2"	2.000	9.15	5.56	3.48	3.13	0.495	



CODE 62 FLANGE 90° BEND RIGID 	PART NUMBER	 HOSE I.D.	 FLANGE	BARB A	O.A.L B	CUT OFF C	DROP E	FLANGE O.D. (inch)	FLANGE THICKNESS
	JJ20-20C62-90	1-1/4"	1-1/4"	1.250	5.65	3.25	2.99	2.13	0.405
JJ20-24C62-90	1-1/4"	1-1/2"	1.250	5.65	3.25	3.06	2.50	0.495	
JJ24-24C62-90	1-1/2"	1-1/2"	1.500	6.31	3.78	3.41	2.50	0.495	
JJ24-32C62-90	1-1/2"	2"	1.500	6.31	3.78	3.53	3.13	0.495	
JJ32-32C62-90	2"	2"	2.000	8.83	5.25	4.88	3.13	0.495	

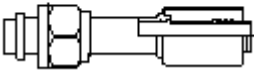

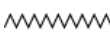
NATIONAL HOSE

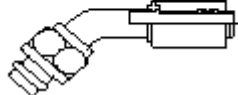

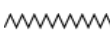

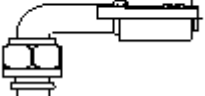
"BL" SERIES REFRIGERANT COUPLINGS FOR BARRIER REFRIGERANT HOSE

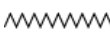

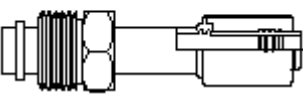

STRAIGHT FEMALE "O" RING SWIVEL	PART NUMBER			BARB A	O.A.L B	CUT OFF C			DROP F
		HOSE I.D.	THREAD				D	E	
	BL06-06TFS	5/16"	5/8"-18						
	BL08-08TFS	13/32"	3/4"-18						
	BL10-10TFS	1/2"	7/8"-18						
	BL12-12TFS	5/8"	1-1/16"-16						

45° FEMALE "O" RING SWIVEL	PART NUMBER			BARB A	O.A.L B	CUT OFF C			DROP F
		HOSE I.D.	THREAD				D	E	
	BL06-06TF45T	5/16"	5/8"-18						
	BL08-08TF45T	13/32"	3/4"-18						
	BL10-10TF45T	1/2"	7/8"-18						
	BL12-12TF45T	5/8"	1-1/16"-16						

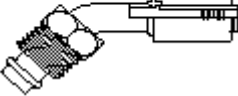
90° FEMALE "O" RING SWIVEL	PART NUMBER			BARB A	O.A.L B	CUT OFF C			DROP F
		HOSE I.D.	THREAD				D	E	
	BL06-06TF90T	5/16"	5/8"-18						
	BL08-08TF90T	13/32"	3/4"-18						
	BL10-10TF90T	1/2"	7/8"-18						
	BL12-12TF90T	5/8"	1-1/16"-16						



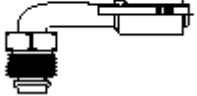

MALE "O" RING SWIVEL	PART NUMBER			BARB A	O.A.L B	CUT OFF C			DROP F
		HOSE I.D.	THREAD				D	E	
	BL06-06TMS	5/16"	5/8"-18						
	BL08-08TMS	13/32"	3/4"-18						
	BL10-10TMS	1/2"	7/8"-18						
	BL12-12TMS	5/8"	1-1/16"-16						



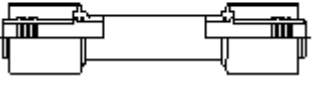

45° MALE "O" RING SWIVEL	PART NUMBER			BARB A	O.A.L B	CUT OFF C			DROP F
		HOSE I.D.	THREAD				D	E	
	BL06-06TM45T	5/16"	5/8"-18						
	BL08-08TM45T	13/32"	3/4"-18						
	BL10-10TM45T	1/2"	7/8"-18						
	BL12-12TM45T	5/8"	1-1/16"-16						



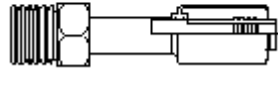

90° MALE "O" RING SWIVEL	PART NUMBER			BARB A	O.A.L B	CUT OFF C			DROP F
		HOSE I.D.	THREAD				D	E	
	BL06-06TM90T	5/16"	5/8"-18						
	BL08-08TM90T	13/32"	3/4"-18						
	BL10-10TM90T	1/2"	7/8"-18						
	BL12-12TM90T	5/8"	1-1/16"-16						

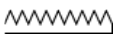

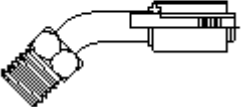

NATIONAL HOSE

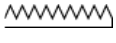

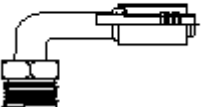

"BL" SERIES REFRIGERANT COUPLINGS FOR BARRIER REFRIGERANT HOSE

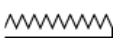

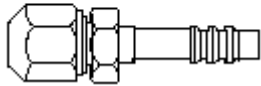

STRAIGHT SPLICER 	PART NUMBER	 HOSE I.D.	 HOSE I.D.	BARB A	O.A.L B	CUT OFF C	 D	 E	DROP F
	BL06-06RM	5/16"	5/16"						
BL08-08RM	13/32"	13/32"							
BL10-10RM	1/2"	1/2"							
BL12-12RM	5/8"	5/8"							

STRAIGHT MALE INSERT "O" RING 	PART NUMBER	 HOSE I.D.	 THREAD	BARB A	O.A.L B	CUT OFF C	 D	 E	DROP F
	BL06-06MOR	5/16"	5/8"-18						
BL08-08MOR	13/32"	3/4"-18							
BL10-10MOR	1/2"	7/8"-18							
BL12-12MOR	5/8"	1-1/16"-16							

45° STRAIGHT MALE INSERT "O" RING 	PART NUMBER	 HOSE I.D.	 THREAD	BARB A	O.A.L B	CUT OFF C	 D	 E	DROP F
	BL06-06MOR45T	5/16"	5/8"-18						
BL08-08MOR45T	13/32"	3/4"-18							
BL10-10MOR45T	1/2"	7/8"-18							
BL12-12MOR45T	5/8"	1-1/16"-16							

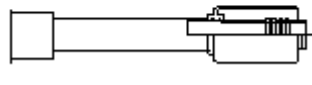

90° STRAIGHT MALE INSERT "O" RING 	PART NUMBER	 HOSE I.D.	 THREAD	BARB A	O.A.L B	CUT OFF C	 D	 E	DROP F
	BL06-06MOR90T	5/16"	5/8"-18						
BL08-08MOR90T	13/32"	3/4"-18							
BL10-10MOR90T	1/2"	7/8"-18							
BL12-12MOR90T	5/8"	1-1/16"-16							



COMPRESSION REPAIR COUPLING 	PART NUMBER	 HOSE I.D.	 TUBE END	BARB A	O.A.L B	CUT OFF C	 D	 E	DROP F
	BL06-06MV	5/16"	5/16"						
BL08-08MV	13/32"	13/32"							
BL10-10MV	1/2"	1/2"							
BL12-12MV	5/8"	5/8"							

BRAZE ON FOR BEADLOCK SYSTEM 	PART NUMBER	 HOSE I.D.	 BRAZE END	BARB A	O.A.L B	CUT OFF C	 D	 E	DROP F
	BL06-06BR	5/16"	5/16"						
BL08-08BR	13/32"	13/32"							
BL10-10BR	1/2"	1/2"							
BL12-12BR	5/8"	5/8"							

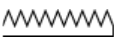
NATIONAL HOSE

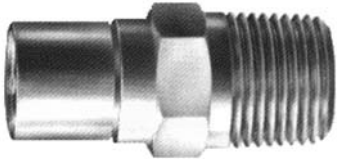
"ST & BR" SERIES SMOOTHBORE COUPLINGS FOR NOMINAL I.D. SMOOTHBORE TEFLON HOSE

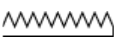

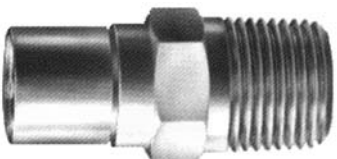
MALE PIPE NPTF RIGID 2 PCS 303 ST/ST FITTING	PART NUMBER			BARB A	O.A.L B	CUT OFF C		
		HOSE I.D.	THREAD				D	E
 <p>316 Stainless Steel Also Available</p>	ST03-0402MP	3/16"	1/8"-27	0.187		0.78		
	ST03-0404MP	3/16"	1/4"-18	0.187		0.96		
	ST03-0504MP	1/4"	1/4"-18	0.250		0.96		
	ST03-0604MP	5/16"	1/4"-18	0.312		0.96		
	ST03-0606MP	5/16"	3/8"-18	0.312		0.99		
	ST03-0806MP	13/32"	3/8"-18	0.406		0.99		
	ST03-0808MP	13/32"	1/2"-14	0.406		1.18		
	ST03-1008MP	1/2"	1/2"-14	0.500		1.20		
	ST03-1212MP	5/8"	3/4"-14	0.625		1.31		
	ST03-1616MP	7/8"	1"-11 1/2	0.875		1.53		



MALE PIPE NPTF RIGID 2 PCS BRASS FITTING	PART NUMBER			BARB A	O.A.L B	CUT OFF C		
		HOSE I.D.	THREAD				D	E
 <p>ALL Brass Carbon Steel Also Available</p>	BR03-0402MP	3/16"	1/8"-27	0.187		0.78		
	BR03-0404MP	3/16"	1/4"-18	0.187		0.96		
	BR03-0502MP	1/4"	1/8"-27	0.250		0.78		
	BR03-0504MP	1/4"	1/4"-18	0.250		0.96		
	BR03-0604MP	5/16"	1/4"-18	0.312		0.96		
	BR03-0606MP	5/16"	3/8"-18	0.312		0.99		
	BR03-0806MP	13/32"	3/8"-18	0.406		0.99		
	BR03-0808MP	13/32"	1/2"-14	0.406		1.18		
	BR03-1008MP	1/2"	1/2"-14	0.500		1.20		
	BR03-1212MP	5/8"	3/4"-14	0.625		1.31		
BR03-1616MP	7/8"	1"-11 1/2	0.875		1.53			

**OUR NEW LINE OF NOMINAL SMOOTHBORE COUPLINGS DO NOT
REQUIRE ANY EXTRA TOOLING OR DIES TO ASSEMBLE COUPLINGS
ON TO ANY SMOOTHBORE HOSES.**

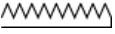
NATIONAL HOSE

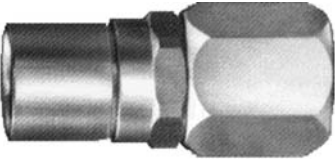
"ST & BR" SERIES SMOOTHBORE COUPLINGS FOR NOMINAL I.D. SMOOTHBORE TEFLON HOSE

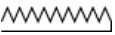
37° JIC FEMALE SWIVEL 2 PCS 303 ST/ST FITTING	PART NUMBER			BARB A	O.A.L B	CUT OFF C		
		HOSE I.D.	THREAD					
 316 Stainless Steel Also Available	ST30-0403FJ	3/16"	3/8"-24	0.187		0.95		
	ST30-0404FJ	3/16"	7/16"-20	0.187		0.95		
	ST30-0505FJ	1/4"	1/2"-20	0.250		1.03		
	ST30-0606FJ	5/16"	9/16"-18	0.312		1.05		
	ST30-0808FJ	13/32"	3/4"-16	0.406		1.15		
	ST30-1010FJ	1/2"	7/8"-14	0.500		1.28		
	ST30-1212FJ	5/8"	1-1/16"-12	0.625		1.47		
	ST30-1616FJ	7/8"	1-5/16"-12	0.875		1.63		

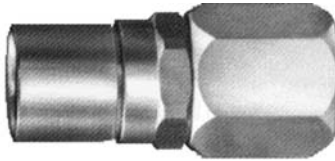

37° JIC FEMALE SWIVEL 2 PCS BRASS FITTING	PART NUMBER			BARB A	O.A.L B	CUT OFF C		
		HOSE I.D.	THREAD					
 ALL Brass Carbon Steel Also Available	BR30-0403FJ	3/16"	3/8"-24	0.187		0.95		
	BR30-0404FJ	3/16"	7/16"-20	0.187		0.95		
	BR30-0505FJ	1/4"	1/2"-20	0.250		1.05		
	BR30-0606FJ	5/16"	9/16"-18	0.312		1.10		
	BR30-0606FS *	5/16"	5/8"-18	0.312		1.08		
	BR30-0808FJ	13/32"	3/4"-16	0.406		1.18		
	BR30-1010FJ	1/2"	7/8"-14	0.500		1.25		
	BR30-1212FJ	5/8"	1-1/16"-12	0.625		1.47		
	BR30-1212FS *	5/8"	1-1/16"-14	0.625		1.50		
	BR30-1616FJ	7/8"	1-5/16"-12	0.875		1.63		

ALL COUPLINGS WITH FS * ARE FOR 45° FEMALE SAE SWIVELS

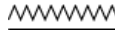

**OUR NEW LINE OF NOMINAL SMOOTHBORE COUPLINGS DO NOT
REQUIRE ANY EXTRA TOOLING OR DIES TO ASSEMBLE COUPLINGS
ON TO ANY SMOOTHBORE HOSES.**

NATIONAL HOSE

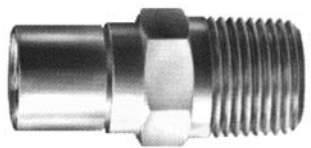
"PF" SERIES PROFLEX COUPLINGS FOR PROFLEX CONVOLUTED TEFLON HOSE

MALE RIGID NPTF PIPE 2 PCS 316 ST/ST FITTING	PART NUMBER			BARB A	O.A.L B	CUT OFF C		
		HOSE I.D.	THREAD				D	E
 316 Stainless Steel Carbon Steel Also Available	PF03-0808MPSS	1/2"	1/2"-14	0.500				
	PF03-1212MPSS	3/4"	3/4"-14	0.750				
	PF03-1616MPSS	1"	1"-11 1/2"	1.000				
	PF03-2020MPSS	1-1/4"	1-1/4"-11 1/2"	1.250				
	PF03-2424MPSS	1-1/2"	1-1/2"-11 1/2"	1.500				
	PF03-3232MPSS	2"	2"-11 1/2"	2.000				

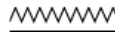
CRIMP COLLAR 316 ST/ST FITTING	PART NUMBER	COLLAR	FOR HOSE
	PFCSS-012	3/4"	PFSS-012
	PFCSS-016	1"	PFSS-016
	PFCSS-020	1-1/4"	PFSS-020
	PFCSS-024	1-1/2"	PFSS-024
	PFCSS-032	2"	PFSS-032

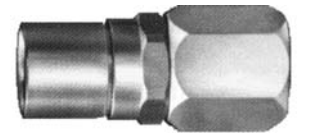
37° JIC FEMALE SWIVEL 2 PCS 316 ST/ST FITTING	PART NUMBER			BARB A	O.A.L B	CUT OFF C		
		HOSE I.D.	THREAD				D	E
 316 Stainless Steel Carbon Steel Also Available	PF30-0808FJSS	1/2"	3/4"-16	0.500				
	PF30-1212FJSS	3/4"	1-1/16"-12	0.750				
	PF30-1616FJSS	1"	1-5/16"-12	1.000				
	PF30-2020FJSS	1-1/4"	1-5/8"-12	1.250				
	PF30-2424FJSS	1-1/2"	1-7/8"-12	1.500				
	PF30-3232FJSS	2"	2-1/2"-12	2.000				

**PLEASE REMEMBER WHEN ORDERING CRIMP ON FITTINGS FOR PROFLEX HOSE
YOU MUST ALSO ORDER THE CORRECT CRIMP ON COLLAR TO FIT!**

NATIONAL HOSE

"D360" SERIES BRASS PUSH-ON COUPLINGS FOR FLEX-LOC PUSH-ON HOSE



PART NUMBER	HOSE I.D.	THREAD
D362-4A	1/4"	1/8"-24
D362-4B	1/4"	1/4"-18
D362-6B	3/8"	1/4"-18
D362-6C	3/8"	3/8"-18
D362-8C	1/2"	3/8"-18
D362-8D	1/2"	1/2"-14
D362-10D	5/8"	1/2"-14
D362-12E	3/4"	3/4"-14



PART NUMBER	HOSE I.D.	THREAD
D367-43	1/4"	3/8"-24
D367-44	1/4"	7/16"-24
D367-45	1/4"	1/2"-20
D367-66	3/8"	5/16"-18
D367-88	1/2"	3/4"-18



PART NUMBER	HOSE I.D.	THREAD
D363-66	3/8"	5/8"-18
D363-1212	3/4"	1-1/16"-14



PART NUMBER	HOSE I.D.	TUBE O.D.
D368-43	1/4"	3/16"
D368-44	1/4"	1/4"
D368-45	1/4"	5/16"
D368-66	3/8"	3/8"
D368-88	1/2"	1/2"



PART NUMBER	HOSE I.D.	THREAD
D364-66	3/8"	5/8"-18
D364-1212	3/4"	1-1/16"-14



PART NUMBER	HOSE I.D.	THREAD
D371-44	1/4"	7/16"-20
D371-45	1/4"	1/2"-20
D371-66	3/8"	9/16"-18
D371-88	1/2"	3/4"-16
D371-1010	5/8"	7/8"-14
D371-1212	3/4"	1-1/16"-12



PART NUMBER	HOSE I.D.	THREAD
D365-44	1/4"	7/16"-20
D365-45	1/4"	1/2"-20
D365-66	3/8"	9/16"-18
D365-88	1/2"	3/4"-16
D365-1010	5/8"	7/8"-14
D365-1212	3/4"	1-1/16"-12



PART NUMBER	HOSE I.D.	HOSE I.D.
D379-44	1/4"	1/4"
D379-66	3/8"	3/8"
D379-88	1/2"	1/2"
D379-1010	5/8"	5/8"
D379-1212	3/4"	3/4"



PART NUMBER	HOSE I.D.	THREAD
D366-43	1/4"	3/8"-24
D366-44	1/4"	7/16"-24
D366-45	1/4"	1/2"-20
D366-66	3/8"	5/16"-18
D366-88	1/2"	3/4"-18

OTHER STYLES OF PUSH-ON HOSE COUPLINGS
ARE AVAILABLE & SOME STYLES ARE AVAILABLE IN
316 STAINLESS STEEL ON REQUEST

NATIONAL HOSE

NEW D100SDC & D105DC SERIES HOSE CRIMPERS

D105DC

35 ton Crimper & Electric Pump
(Complete With 7 Dies & Storage Shelf)



D100SDC

Portable Crimper
Only (No Dies) or
Pump



D100 Series Standard & Optional Die Information

SPLIT DIE PART #	DIE SIZE & COLOR-CODE
D100-020-0520	0.520 RD
D100-020-0670	0.670 YL
D100-020-0830	0.830 BL
D100-020-1100	1.100 GR
D100-020-1320	1.320 BK
D100-020-1500	1.500 BR
D100-020-1730	1.730 SL
OPTIONAL DIE SETS #	DIE SIZE & COLOR-CODE
D100-020-0315	0.315 OR
D100-020-0350	0.350 OR
D100-020-0995	0.995 OR
D100-035-0580 (Bubble)	0.580 OR
D100-035-0850 (Bubble)	0.850 OR

Crimper Capability: This Unit delivers a rugged 35 Tons of force through 7 standard Die sets And let's you crimp Any 1 & 2 wire braided hoses from 3/16" to 1-1/4" I.D. & 4 Spiral wire hoses From 3/8" to 1" I.D. All D100DC & D105DC series crimpers have four strain rods to help provide accurate crimps each time.

- All New - 1hp 110volt Single Phase 10,000 psi electric pump for (D105DC units only)
For D100DC units pump options are: Pneumatic, Electric 1/4hp 110v & Hand pump
- All New - "DC" Micrometer style crimp settings & precise visual indicator makes accurate & consistent Crimps time after time.
- All New - Easy To Do Recalibration check only requires 2 wrench (no allen keys needed)
- All New - Style Inverted Split Dies Help With Improved Visibility & Safty When Operating With The Color Coded & Numbered Die System (Because Safty Comes First)
- All New - Powerful magnets in the pusher will retract the compression plate with the pusher.
- All New - Compact desigine makes this unit even more value added when theres not much room available!

Special Features: Our "DC" series crimpers come with the same Size Die's & Colour coded die rings as DAYCO Series Crimpers. It also can be set to the same settings in most cases on the Micrometer to give you the same crimp O.D.'s That Dayco offered. (Please Contact National Hose & Equipment For Upto Date Crimp Specs & Infomation About This System).

NATIONAL HOSE

NEW D205DC SERIES HOSE CRIMPERS

D205DC

80 Ton Crimper & 2HP 220Volt Electric Pump
(Complete With 9 Die Sets & Storage Shelf)

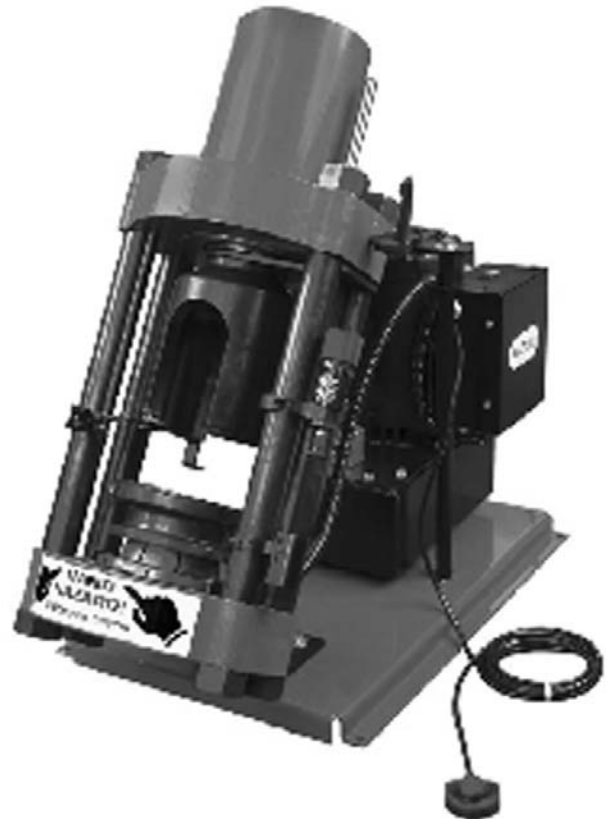

Standard & Optional Die Information

SPLIT DIE PART #	DIE SIZE & COLOR-CODE
D200-020-0520	0.520 RD
D200-020-0670	0.670 YL
D200-020-0830	0.830 BL
D200-020-1100	1.100 GR
D200-020-1320	1.320 BK
D200-020-1500	1.500 BR
D200-020-1730	1.730 SL
D200-020-1920	1.920 PR
D200-020-2200	2.200 BR
OPTIONAL DIE SETS #	DIE SIZE & COLOR-CODE
DA200-032-2800	2.800 BK
D200-020-1850	1.850 OR
D200-020-0315	0.315 OR
D200-020-0350	0.350 OR
D200-020-0995	0.995 OR
D200-035-0580 (Bubble)	0.580 OR
D200-035-0850 (Bubble)	0.850 OR

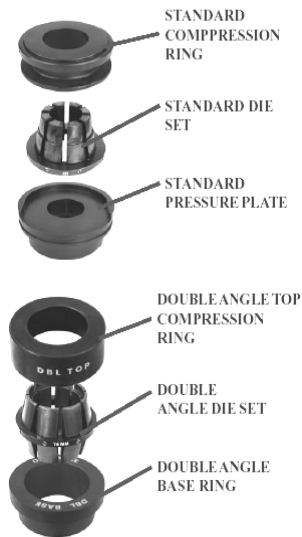

Crimper Capability: This Unit delivers a rugged 80 Tons of force through 9 standard Die sets. And let's you crimp Any 1 & 2 wire braided hoses from 3/16" to 1-1/2" I.D. And all 4 & 6 Spiral wire hoses From 3/8" to 1-1/2" I.D. And with the optional DA200-032-2800 Double Angle die 2" braided & spiral wire hoses are no problem, All D205DC series crimpers have four strain rods to help provide accurate crimps each time.

- All New - 2hp 220volt Single Phase 50/60Hz Low Amp 10,000 Psi Electric Pump for (D205DC units only)
- All New - "DC" Micrometer Style Crimp Settings & Precise Visual Indicator Makes Accurate & Consistent Crimps Time After Time.
- All New - Easy To Do Recalibration check only requires 2 wrench (no allen keys needed)
- All New - Style Inverted Split Dies Help With Improved Visibility & Safty When Operating With The Color Coded & Numbered Die System (Because Safty Comes First)
- All New - "DA" Double Angle Dies Double The Radial Crimping Force Allowing Heavier Crimp Fittings To Be Crimped
- All New - Powerful magnets in the pusher will retract the compression plate with the pusher.
- All New - Compact desigine makes this unit even more value added when theres not much room available!

Special Features: Our "DC" series crimpers come with the same Size Die's & Colour coded die rings as DAYCO Series Crimpers. It also can be set to the same settings in most cases on the Micrometer to give you the same crimp O.D.'s That Dayco offered. (Please Contact National Hose & Equipment For Upto Date Crimp Specs & Infomation About This System).

NATIONAL HOSE

PROTECTION PRODUCTS & ACCESSORIES
What You Need To Protect Your Investments!



Hose Covers & Wraps

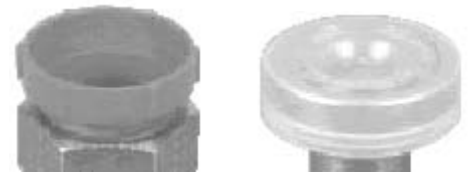

NATIONAL HOSE

STRAIN RELIEVERS & COVER PROTECTION PRODUCTS “ POLYGUARD & NYLON HOSE SLEEVING ”



POLYGUARD HOSE STRAIN RELIEVERS

Application: To be used on the end of assemblies
To help reduce bending stress & extending hose life

Tube & Cover: 1pcs Black Vinyl

Temp. Range: -40°C to +120°C or (-40°F to +250°F)

**Comes in Broken Packs of 10 to 100pcs or
Standard pack boxes.**

PART NUMBER	Inside Dia. OF Guard (inch)	Over All Length OF Guard (inch)	Fits Hoses Sizes	Broken Pack QTY	Standard Pack QTY
PG-625	0.625	5.20	-4 & -6	100	300
PG-678	0.678	5.74	-6	100	300
PG-761	0.761	6.43	-6 & -8	50	175
PG-827	0.827	6.98	-8	50	175
PG-885	0.885	7.76	-8	25	150



NYLON HOSE SLEEVE

Application: To be used for hose cover protection &
To protect machinery & people from hoses that have
burst and pinhole occurrences - MSHA approved

Tube & Cover: 1pcs Nylon tight knit weaving

Temp. Range: -40°C to +120°C or (-40°F to +250°F)

Comes in cut lengths or Standard coil lengths.

PART NUMBER	Inside Dia. OF Sleeve (inch)	Outside Dia Flat With Sleeve (inch)	Wall Doubled Flat Thickness (inch)	Standard Coil Length
NHS-090	.90"	1.50"	.090"	100' & 300'
NHS-114	1.14"	1.88"	.090"	100' & 300'
NHS-125	1.25"	2.03"	.090"	100' & 300'
NHS-138	1.38"	2.25"	.090"	100' & 300'
NHS-159	1.59"	2.56"	.090"	100' & 300'
NHS-175	1.75"	2.81"	.090"	100' & 300'
NHS-185	1.85"	3.00"	.090"	100' & 300'
NHS-207	2.07"	3.31"	.090"	100' & 300'
NHS-225	2.25"	3.63"	.090"	100' & 300'
NHS-238	2.38"	3.81"	.090"	100' & 300'
NHS-254	2.54"	4.06"	.090"	100' & 300'
NHS-264	2.64"	4.25"	.090"	100' & 300'
NHS-334	3.34"	5.31"	.090"	100' & 300'

NATIONAL HOSE

COVER PROTECTION PRODUCTS "TECTORGUARD SERIES SPIRAL HOSE WRAP"



TECTORFLEX LIGHT DUTY HOSE WRAP

Application: To be used on hoses for cover protection
& also used for bundling many hose as one

Tube & Cover: Cellulose acetate (shine surface)
Temp. Range: -34°C to +182°C or (-30°F to +185°F)
Comes in cut lengths or Standard coil lengths.



PART NUMBER	Inside Dia. OF Guard (inch)	Fits Over 1 Wire Braid Dash Sizes	Fits Over 2 Wire Braid Dash Sizes	Fits Over Thermoplastic Dash Sizes	Fits Over 4 & 6 Spiral Dash Sizes	Fits Over 6 Spiral Wire Dash Sizes	Standard Coil Length
TFG-08-H	0.25"	-	-	-2	-	-	40'
TFG-12-H	0.37"	-	-	-3	-	-	40'
TFG-16-H	0.50"	-4 & -5	-4	-4 & -5	-	-	40'
TFG-20-H	0.62"	-6	-5	-6	SGX Series	SGX Series	40'
TFG-25-H	0.75"	-8	-6 & -8	-8	SGX Series	SGX Series	40'
TFG-32-H	1.00"	-10 & -12	-10 & -12	-10 & -12	SGX Series	SGX Series	40'
TFG-44-H	1.38"	-16	-16	-16	SGX Series	SGX Series	40'
TFG-56-H	1.75"	-20	-20	-20	SGX Series	SGX Series	40'
TFG-82-H	2.56"	-24 & -32	-24 & -32	-24	SGX Series	SGX Series	40'
TFG-95-H	3.15"	-40	-40	-40	-	-	40'



TECTORGUARD MEDIUM & HEAVY DUTY HOSE WRAP

Application: To be used on hoses for cover protection
& also used for bundling many hose as one

Tube & Cover: High Density Polyethylene (HDPE)
Temp. Range: -73°C to +104°C or (-100°F to +220°F)
Comes in cut lengths or in standard coil length.



PART NUMBER	Inside Dia. OF Guard (inch)	Fits Over 1 Wire Braid Dash Sizes	Fits Over 2 Wire Braid Dash Sizes	Fits Over Thermoplastic Dash Sizes	Fits Over 4 Spiral Wire Dash Sizes	Fits Over 6 Spiral Wire Dash Sizes	Standard Coil Length
SGX-20-M	0.66"	-4 -5 & -6	-4 -5 & -6	-6 & -8	-6	-	100'
SGX-32-M	1.00"	-8 -10 & -12	-8 -10 & -12	-10 & -12	-8 & -10	-	100'
SGX-39-H	1.25"	-	-	-16	-12	-12	100'
SGX-45-H	1.50"	-16	-16	-16 sewer hose	-16	-16	100'
SGX-50-M	1.60"	-20	-	-20 sewer hose	-20	-	50'
SGX-59-H	2.00"	-24	-20 & -24	-24 sewer hose	-24	-20 & -24	100'
SGX-75-M	2.50"	-32	-32	-	-32	-32	50'
SGX-90-M	3.00"	-40	-	-	-	-	35'
SGX-102-H	3.50"	-	-40	-	-	-	30'
SGX-114-H	4.00"	FOR SINGLE OR TO BUNDLE GROUPS OF HOSES					
SGX-165-H	6.00"						

NATIONAL HOSE

COVER PROTECTION PRODUCTS “ SILICONE RUBBER FIBERGLASS SLEEVING “



SILICONE FIRE SLEEVE

Application: To be used for hose cover protection & High heat applications, also helps to insulate energy loss In hose & piping systems (**protects employees from burns**)

Tube: Fiberglass (type E) knitted braided

Cover: Silicone rubber industrial grade red

Temp. Range: -54°C to +260°C or (-65°F to +500°F)

Comes in 50' or 100' lengths only.

PART NUMBER	Inside Dia. OF Sleeve (inch)	Fits Hose O.D.s With Dash Sizes	Wall Doubled Flat Thickness (inch)	Standard Coil Length
SFS-250	.250"	-4	.300"	50' & 100'
SFS-375	.375"	-6	.300"	50' & 100'
SFS-500	.500"	-8	.300"	50' & 100'
SFS-625	.625"	-10	.300"	50' & 100'
SFS-750	.750"	-12	.300"	50' & 100'
SFS-875	.875"	-14	.300"	50' & 100'
SFS-100	1.00"	-16	.300"	50' & 100'
SFS-1125	1.125"	-18	.300"	50' & 100'
SFS-1250	1.250"	-20	.300"	50' & 100'
SFS-1375	1.375"	-22	.300"	50' & 100'
SFS-1500	1.500"	-24	.300"	50' & 100'
SFS-1625	1.625"	-26	.300"	50' & 100'
SFS-1750	1.750"	-28	.300"	50' & 100'
SFS-2000	2.00"	-32	.300"	50' & 100'
SFS-2250	2.25"	-36	.300"	50' & 100'
SFS-2500	2.50"	-40	.300"	50' & 100'
SFS-2750	2.75"	-44	.300"	50' & 100'
SFS-3000	3.00"	-48	.300"	50' & 100'

NATIONAL HOSE

ULTRA CLEAN HOSE, TUBE & PIPE CLEAN OUT SYSTEM

UC-EL-7DP Economy Launcher Kit



Kit # UC-EL-7DP (as shown here)
Can Clean Hose, Tube & Pipe Sizes from
1/8" I.D. Through 1-1/4" I.D.

The Fluid Power Industry has struggled to eliminate contamination in hydraulic systems for years. Manufacturers of hydraulic components have sacrificed warranty claims due to contamination as part of doing business. Research has proven that clean oil and clean hydraulic systems are key to longer system life and less downtime. But what happens to clean oil once it travels through newly installed hose & tube assemblies? The particles or contamination left behind from the cutting, crimping, bending & flaring process are a real problem. **THEY MUST BE REMOVED!!!!**



Attempts have been made to solve this problem by using chemicals, high pressure flushing & old pull through techniques with only marginal results. So, let's make this simple! Clean oil and

clean **Hose & Tube assemblies** at start up can eliminate 80% of hydraulic system failures. Now NATIONAL HOSE offers an inexpensive & fast way to eliminate the contamination from hose & tube. Using a specially formulated Projectile and our Ultra Clean System you can clean away the contamination from hoses, tubes & pipes in seconds. It's simple just fire the Projectile 20% to 30% larger than the I.D. of hose, tube or pipe and the Ultra Clean Projectile cleans out the internal contamination as it travels through couplings & around bends forcing the contamination out in front of it. Now you have an **ULTRA CLEAN** assembly to put into service.

This Kit Includes:

- 1 UC-EL Economy Launcher
- 7 Hose Nozzles or 7 Nozzles of your choice (**Standard with Hose Nozzles**)
- 1 Quick Disconnect Coupling & Heavy Duty Carry Case
- 1 UC-P1 Ultra Clean Projectile Kit (**In Bag's**)
- 1 Catcher Bucket & Ultra Clean Info Poster

1) Load Nozzle & Projectile



2) Screw on Head



3) Connect Air Hose



4) Squeeze Lever & Your Done



NATIONAL HOSE

"ENVIRO SAFE" HAND CLEANERS & DEGREASER - AW-SERIES HYDRAULIC OILS & OIL ABSORBENT



PART #	SIZE	DESCRIPTION	PER CASE
KOOL GREEN HAND CLEANER WITH GRIT			
KG4P	3.78 Litre	PUMP JUG	4
KG20L	20 Litre	PAIL	1
BLACKOUT HAND CLEANER WITH GRIT			
BOG4V	3.78 Litre	CAN	4
BOG4T	3.78 Litre	TUB	4
BOG20L	20 Litre	PAIL	1
CITRUS POWER DEGREASER			
CP4L	4 Litre	JUG	4
CP20L	20 Litre	PAIL	1
CP205L	205 Litre	DRUM	1
HAND PUMP DISPENSERS			
AR125	3.78 Litre	Dispenser for pump jug	1
ASC-S	3.78 Litre	Dispenser for blackout can	1

AW SERIES HYDRAULIC OIL	PART #	SIZE	DESCRIPTION	PACKAGE QTY EACH	PACKAGE SKID QTY BULK	CSA-50 OIL ABSORBENT
	AW SERIES HYDRAULIC OIL					
	AW-32	20 Litre Pail	HYDRAULIC OIL	1	36	
	AW-46	20 Litre Pail	HYDRAULIC OIL	1	36	
	AW-68	20 Litre Pail	HYDRAULIC OIL	1	36	
CSA SERIES PREMIUM OIL ABSORBENT						
CSA-50	50 lbs Bag	SAFE-T-ABSORBENT	1	45		

NATIONAL HOSE

FRACTION CONVERSION CHART

FRACTION TO DECIMAL TO MILLIMETERS

INCHES		mm
1/64	0.0156	0.397
1/32	0.0312	0.792
3/64	0.0468	1.189
1/16	0.0625	1.588
5/64	0.0781	1.984
3/32	0.0937	2.380
7/64	0.1093	2.776
1/8	0.1250	3.175
9/64	0.1406	3.572
5/32	0.1562	3.967
11/64	0.1718	4.364
3/16	0.1875	4.763
13/64	0.2031	5.159
7/32	0.2187	5.555
15/64	0.2343	5.951
1/4	0.2500	6.350
17/64	0.2656	6.747
9/32	0.2812	7.142
19/64	0.2968	7.539
5/16	0.3125	7.938
21/64	0.3281	8.334
11/32	0.3437	8.730
23/64	0.3593	9.126
3/8	0.3750	9.525
25/64	0.3906	9.922
13/32	0.4062	10.317
27/64	0.4218	10.714
7/16	0.4375	11.113
29/64	0.4531	11.509
15/32	0.4687	11.905
31/64	0.4843	12.301
1/2	0.5000	12.700

INCHES		mm
33/64	0.5156	13.097
17/32	0.5312	13.492
35/64	0.5468	13.889
9/16	0.5625	14.288
37/64	0.5781	14.684
19/32	0.5937	15.080
39/64	0.6093	15.476
5/8	0.6250	15.875
41/64	0.6406	16.272
21/32	0.6562	16.667
43/64	0.6718	17.064
11/16	0.6875	17.463
45/64	0.7031	17.859
23/32	0.7187	18.255
47/64	0.7343	18.651
3/4	0.7500	19.050
49/64	0.7656	19.447
25/32	0.7812	19.842
51/64	0.7968	20.239
13/16	0.8125	20.638
53/64	0.8281	21.034
27/32	0.8437	21.430
55/64	0.8593	21.826
7/8	0.8750	22.225
57/64	0.8906	22.622
29/32	0.9062	23.017
59/64	0.9218	23.414
15/16	0.9375	23.813
61/64	0.9531	24.209
31/32	0.9687	24.605
63/64	0.9843	25.001
1	1.0000	25.400

NATIONAL HOSE

CONVERSION FACTORS CHART

	TO CONVERT	→ INTO →	MULTIPLY BY
PRESSURE	1 Pound per square-inch	bar	0.06895
	1 bar	psi	14.5035
	1 Pound per square-inch	MPa	0.006895
	1 mega pascal	psi	145.035
	1 kilo pascal	bar	0.01
	1 bar	kPa	100
	1 mega pascal	bar	10
	1 bar	MPa	0.1
LENGTH	1 inch	mm	25.4
	1 millimetre	in	0.03934
	1 foot	m	0.3048
	1 metre	ft	3.28084
AREA	1 square-inch	cm ²	6.4516
	1 cubic centimetre	sq in	0.1550
VOLUME	1 gallon (UK)	litre	4.54596
	1 litre	gallon (UK)	0.219976
	1 gallon (US)	litre	3.78533
	1 litre	gallon (US)	0.264177
WEIGHT	1 pound	kg	0.453592
	1 kilogramme	lb	2.204622
FLOW RATE	1 gallon per minute (UK)	litre / min	0.54596
	1 litre per minute	gallon / min (UK)	0.219976
	1 gallon per minute (US)	litre / min	3.78533
	1 litre per minute	gallon / min (US)	0.264178
VELOCITY	1 foot per second	metre / sec	0.3048
	1 metre per second	ft / sec	3.280840
TEMPERATURE	Fahrenheit degree	°C	(°F -32) x .555
	Celsius degree	°F	(°C x 1.8) +32
POWER	horse-power	BTU's / min	42.44
	horse-power	ft-lbs / min	33,000
	horse-power	ft-lbs / sec	550
	horse-power	hp (metric)	1.014
	horse-power	kws	0.7457
	horse-power	watts	745.7

VELOCITY OF FLOW THROUGH PIPES:

$$V = \frac{\text{GPM} \times 0.3208}{A}$$

V = Velocity in feet per second
A = Inside opening area in (in²)

HEAD PRESSURE:

Oil creates a pressure due to its weight of 0.4 PSI per foot of depth

PRESSURE DROP THROUGH PIPES:

$$P = \frac{V \times F}{18300 D}$$

P = Pressure drop per foot
V = Viscosity in sus
D = Inside diameter (inches)
F = Flow in gpm

HEAT GENERATION:

BTU/hr = 1.5 x GPM x PSI
PSI = Pressure loss which does not produce work

NATIONAL HOSE

PRESSURE CONVERSION CHART

PSI TO METRIC				METRIC TO PSI			
(PSI)	(kPa)	(MPa)	(Bar)	(kPa)	(MPa)	(Bar)	(PSI)
10	69.0	0.07	0.7	100	0.1	1	14.5
20	137.9	0.14	1.4	200	0.2	2	29.0
30	206.9	0.21	2.1	300	0.3	3	43.5
40	275.8	0.28	2.8	400	0.4	4	58.0
50	344.8	0.34	3.4	500	0.5	5	72.5
60	413.7	0.41	4.1	600	0.6	6	87.0
70	482.7	0.48	4.8	700	0.7	7	101.5
80	551.6	0.55	5.5	800	0.8	8	116.0
90	620.6	0.62	6.2	900	0.9	9	130.5
100	690	0.7	6.9	1,000	1.0	10	145.0
200	1,379	1.4	13.8	2,000	2.0	20	290.1
300	2,069	2.1	20.7	3,000	3.0	30	435.1
400	2,758	2.8	27.6	4,000	4.0	40	580.1
500	3,448	3.4	34.5	5,000	5.0	50	725.2
600	4,137	4.1	41.4	6,000	6.0	60	870.2
700	4,827	4.8	48.3	7,000	7.0	70	1,015
800	5,516	5.5	55.2	8,000	8.0	80	1,160
900	6,206	6.2	62.1	9,000	9.0	90	1,305
1,000	6,895	6.9	69.0	10,000	10.0	100	1,450
2,000	13,790	13.8	137.9	20,000	20.0	200	2,901
3,000	20,685	20.7	206.9	30,000	30.0	300	4,351
4,000	27,580	27.6	275.8	40,000	40.0	400	5,801
5,000	34,475	34.5	344.8	50,000	50.0	500	7,252
6,000	41,370	41.4	413.7	60,000	60.0	600	8,702
7,000	48,265	48.3	482.7	70,000	70.0	700	10,152
8,000	55,160	55.2	551.6	80,000	80.0	800	11,603
9,000	62,055	62.1	620.6	90,000	90.0	900	13,053
10,000	68,950	69.0	690	100,000	100	1000	14,504
20,000	137,900	137.9	1,379	200,000	200	2000	29,007
30,000	206,850	206.9	2,069	300,000	300	3000	43,511
40,000	275,800	275.8	2,758	400,000	400	4000	58,014

(PSI): POUNDS PER SQUARE INCH

(kPa): KILO PASCALS

(MPa): MEGA PASCALS

(Bar): BAR

NATIONAL HOSE

FITTING THREAD SIZE MATCH UP CHART

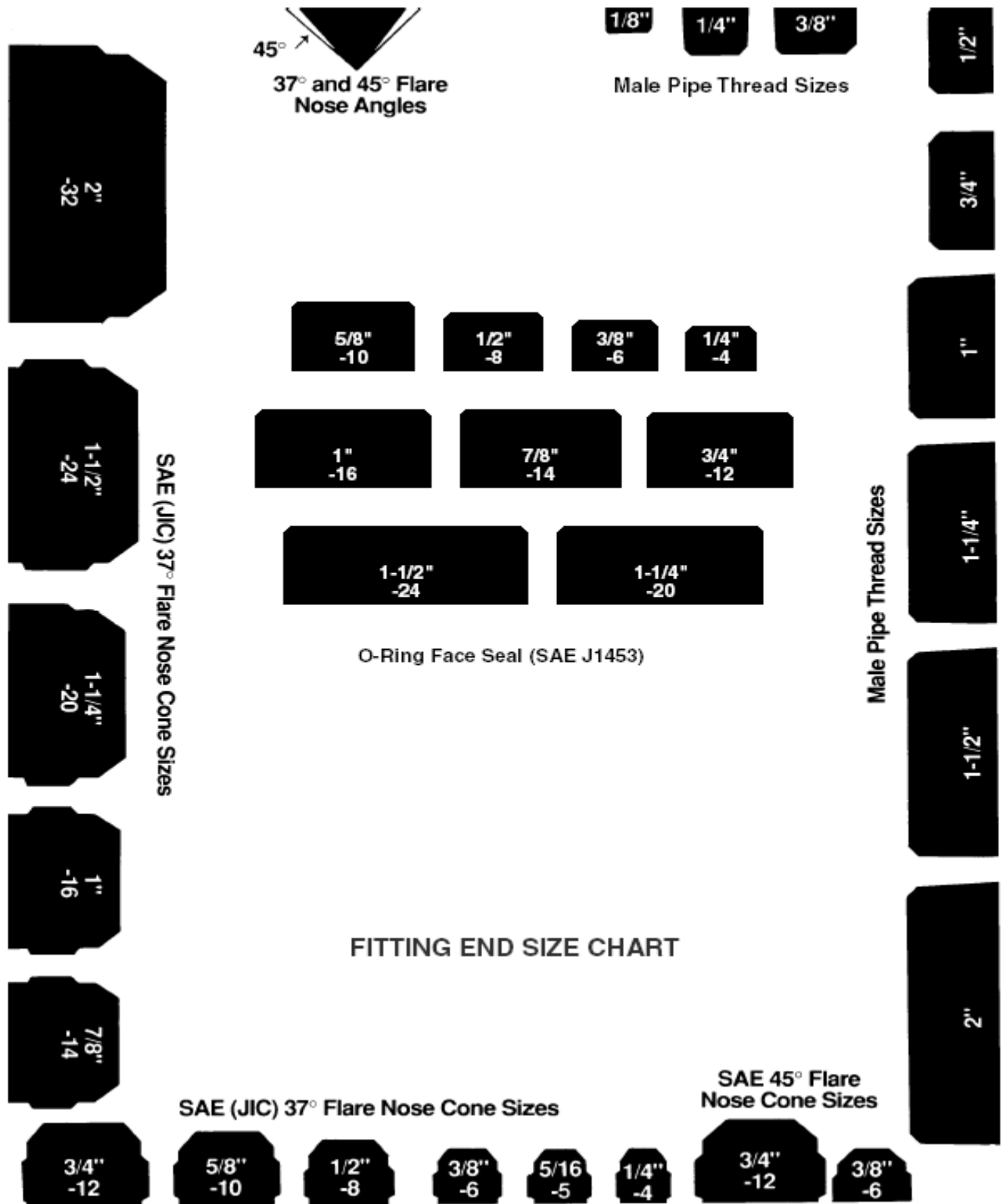

NATIONAL HOSE

FITTING HEX & FLANGE SIZE MATCH UP CHART

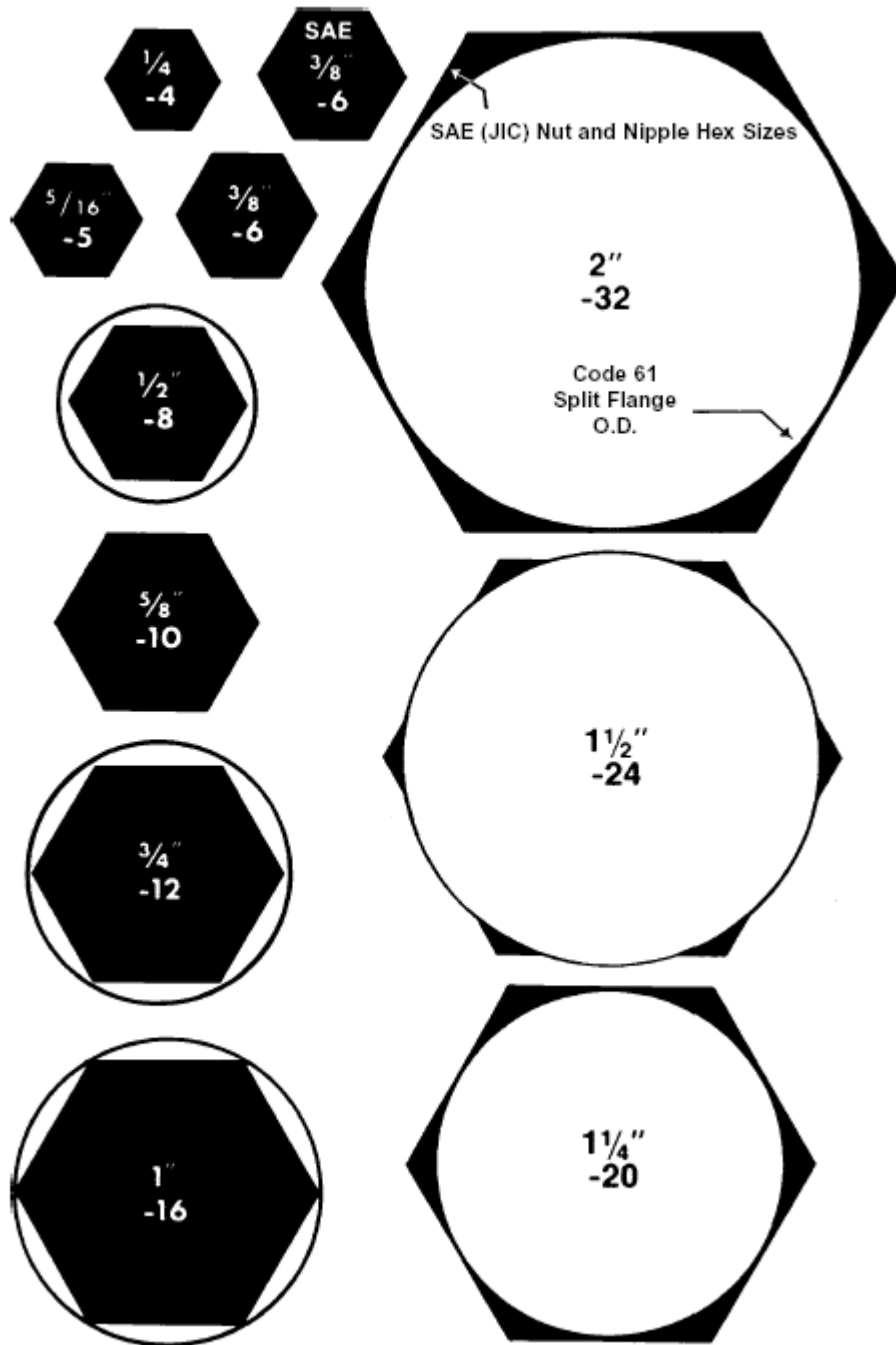

NATIONAL HOSE

NEW PART NUMBER INDEX

PART#	Product Style	Page #	PART#	Product Style	Page #
4SH	Hose Product	35	NH-FSX90	Braided Hose Coupling	43
4SP	Hose Product	35	NH-FW	Braided Hose Coupling	44
AU-05	Hose Product	27	NH-JISX	Braided Hose Coupling	48
AMI	Hose Product	24	NH-KAR	Braided Hose Coupling	44
BXI	Hose Product	23	NH-KOMX	Braided Hose Coupling	48
CEI	Hose Product	35	NH-MB	Braided Hose Coupling	40
FXI	Hose Product	24	NH-MBX	Braided Hose Coupling	40
HPS	Hose Product	33	NH-MBX90	Braided Hose Coupling	41
JL	Hose Product	25	NH-MIX	Braided Hose Coupling	49
MXI	Hose Product	23	NH-MIX45	Braided Hose Coupling	49
N2I	Hose Product	36	NH-MIX90	Braided Hose Coupling	49
NHI	Hose Product	36	NH-MJ	Braided Hose Coupling	40
PFI	Hose Product	25	NH-MP	Braided Hose Coupling	37
PFSS	Hose Product	32	NH-MPX	Braided Hose Coupling	37
PW	Hose Product	26	NH-MPX90	Braided Hose Coupling	37
PWHP	Hose Product	26	NH-MS	Braided Hose Coupling	43
PW-NM	Hose Product	26	NH-MT	Braided Hose Coupling	42
R4	Hose Product	27	NH-MW	Braided Hose Coupling	44
R7	Hose Product	29	NH-SHELL	Braided Hose Coupling	44
R7-NC	Hose Product	29	DS-L	Metric Sleeve	57
R7TL	Hose Product	30	DS-L/S	Metric Sleeve	57
R7TL-NC	Hose Product	30	DS-S	Metric Sleeve	57
R8	Hose Product	31	M-L	Metric Nut	57
R8-NC	Hose Product	31	M-S	Metric Nut	57
T1	Hose Product	32	TC-BFPX	Non-Skive Coupling	54
WB	Hose Product	34	TC-BSPX	Non-Skive Coupling	54
XHPS	Hose Product	33	TC-BSPX45	Non-Skive Coupling	54
XWB	Hose Product	34	TC-BSPX90	Non-Skive Coupling	54
NH-BFPX	Braided Hose Coupling	45	TC-C61	Non-Skive Coupling	53
NH-BSPP	Braided Hose Coupling	45	TC-C61-45	Non-Skive Coupling	53
NH-BSPT	Braided Hose Coupling	46	TC-C61-90	Non-Skive Coupling	53
NH-BSPX	Braided Hose Coupling	45	TC-FFX	Non-Skive Coupling	52
NH-BSPX45	Braided Hose Coupling	45	TC-FFX45	Non-Skive Coupling	52
NH-BSPX90	Braided Hose Coupling	45	TC-FFX90	Non-Skive Coupling	52
NH-C61	Braided Hose Coupling	43	TC-FJX	Non-Skive Coupling	50
NH-DINH	Braided Hose Coupling	47	TC-FJX45	Non-Skive Coupling	50
NH-DINHX	Braided Hose Coupling	47	TC-FJX90	Non-Skive Coupling	51
NH-DINHX45	Braided Hose Coupling	47	TC-GAZX	Non-Skive Coupling	55
NH-DINHX90	Braided Hose Coupling	47	TC-JISX	Non-Skive Coupling	55
NH-DINL	Braided Hose Coupling	46	TC-KOMX	Non-Skive Coupling	55
NH-DINLX	Braided Hose Coupling	46	TC-MB	Non-Skive Coupling	51
NH-DINLX45	Braided Hose Coupling	46	TC-MJ	Non-Skive Coupling	51
NH-DINLX90	Braided Hose Coupling	46	TC-MP	Non-Skive Coupling	50
NH-FFX	Braided Hose Coupling	41	TC-MPX	Non-Skive Coupling	50
NH-FFX45	Braided Hose Coupling	41	TC-MSP	Non-Skive Coupling	56
NH-FFX90	Braided Hose Coupling	42	TC-MSP45	Non-Skive Coupling	56
NH-FFX90L	Braided Hose Coupling	42	TC-MSP90	Non-Skive Coupling	57
NH-FJX	Braided Hose Coupling	38	BW-BSPX	Non-Skive Coupling	65
NH-FJX45	Braided Hose Coupling	39	BW-BSPX45	Non-Skive Coupling	65
NH-FJX90	Braided Hose Coupling	39	BW-BSPX90	Non-Skive Coupling	65
NH-FJX90L	Braided Hose Coupling	39	BW-C61	Non-Skive Coupling	61
NH-FP	Braided Hose Coupling	38	BW-C61-22	Non-Skive Coupling	61
NH-FPX	Braided Hose Coupling	38	BW-C61-30	Non-Skive Coupling	61
NH-FSX	Braided Hose Coupling	43	BW-C61-45	Non-Skive Coupling	62
NH-FSX45	Braided Hose Coupling	43	BW-C61-60	Non-Skive Coupling	62

NATIONAL HOSE

-----NEW PART NUMBER INDEX-----

PART#	Product Style	Page #	PART#	Product Style	Page #
BW-C61-90	Non-Skive Coupling	62	BL-TFS	A/C Coupling	70
BW-C62	Non-Skive Coupling	63	BL-TM45T	A/C Coupling	70
BW-C62-22	Non-Skive Coupling	63	BL-TM90T	A/C Coupling	70
BW-C62-30	Non-Skive Coupling	63	BL-TMS	A/C Coupling	70
BW-C62-45	Non-Skive Coupling	64	BR-FJ	S.B. Teflon Coupling	73
BW-C62-60	Non-Skive Coupling	64	BR-FS	S.B. Teflon Coupling	73
BW-C62-90	Non-Skive Coupling	64	BR-MP	S.B. Teflon Coupling	72
BW-CAT	Non-Skive Coupling	T.B.A	PFCSS	Con Teflon Crimp Shell	74
BW-CAT-22	Non-Skive Coupling	T.B.A	PF-FJSS	Con Teflon Coupling	74
BW-CAT-30	Non-Skive Coupling	T.B.A	PF-MPSS	Con Teflon Coupling	74
BW-CAT-45	Non-Skive Coupling	T.B.A	ST-FJ	S.B. Teflon Coupling	73
BW-CAT-60	Non-Skive Coupling	T.B.A	ST-MP	S.B. Teflon Coupling	72
BW-CAT-67	Non-Skive Coupling	T.B.A	D362	Push On Fitting	75
BW-CAT-90	Non-Skive Coupling	T.B.A	D363	Push On Fitting	75
BW-FFX	Non-Skive Coupling	60	D364	Push On Fitting	75
BW-FFX45	Non-Skive Coupling	60	D365	Push On Fitting	75
BW-FFX90	Non-Skive Coupling	60	D366	Push On Fitting	75
BW-FJX	Non-Skive Coupling	59	D367	Push On Fitting	75
BW-FJX45	Non-Skive Coupling	59	D368	Push On Fitting	75
BW-FJX90	Non-Skive Coupling	59	D371	Push On Fitting	75
BW-JISX	Non-Skive Coupling	64	D379	Push On Fitting	75
BW-KOMX	Non-Skive Coupling	64	D100SDC	Equipment & Tooling	76
BW-MB	Non-Skive Coupling	58	D105DC	Equipment & Tooling	76
BW-MJ	Non-Skive Coupling	58	D205DC	Equipment & Tooling	77
BW-MP	Non-Skive Coupling	58	AR125	Dispenser For Jug's	83
JJ-C61	Skive Coupling	67	ASC-S	Dispenser For Can's	83
JJ-C61-22	Skive Coupling	67	AW-32	Hydraulic Oil	83
JJ-C61-30	Skive Coupling	67	AW-46	Hydraulic Oil	83
JJ-C61-45	Skive Coupling	67	AW-68	Hydraulic Oil	83
JJ-C61-60	Skive Coupling	67	BOG20L	Hand Cleaners	83
JJ-C61-67	Skive Coupling	68	BOG4T	Hand Cleaners	83
JJ-C61-90	Skive Coupling	68	BOG4V	Hand Cleaners	83
JJ-C62	Skive Coupling	68	CP205L	Degreaser	83
JJ-C62-22	Skive Coupling	68	CP20L	Degreaser	83
JJ-C62-30	Skive Coupling	68	CP4L	Degreaser	83
JJ-C62-45	Skive Coupling	69	CSA-50	Safe-T-Oil Absorbent	83
JJ-C62-60	Skive Coupling	69	KG20L	Hand Cleaners	83
JJ-C62-67	Skive Coupling	69	KG4P	Hand Cleaners	83
JJ-C62-90	Skive Coupling	69	MPTC	Plastic Caps & Plugs	T.B.A
JJ-FFX	Skive Coupling	66	MTTC	Plastic Caps & Plugs	T.B.A
JJ-FFX45	Skive Coupling	66	NHS	Nylon Hose Sleeve	79
JJ-FFX90	Skive Coupling	66	PFC61	Plastic Caps & Plugs	T.B.A
JJ-FJX	Skive Coupling	66	PFC62	Plastic Caps & Plugs	T.B.A
JJ-FJX45	Skive Coupling	66	PFP	Plastic Caps & Plugs	T.B.A
JJ-FJX90	Skive Coupling	66	PG	Strain Relievers	79
JJ-MJ	Skive Coupling	66	SFS	Silicone Fire Sleeve	81
JJ-MP	Skive Coupling	66	SGX	Heavy Duty Hose Wrap	80
BL-BR	A/C Coupling	71	TCMJ	Plastic Caps & Plugs	T.B.A
BL-MOR	A/C Coupling	71	TCMP	Plastic Caps & Plugs	T.B.A
BL-MOR45T	A/C Coupling	71	TFG	Light Duty Hose Wrap	80
BL-MOR90T	A/C Coupling	71	TPFJ	Plastic Caps & Plugs	T.B.A
BL-MV	A/C Coupling	71	TPFP	Plastic Caps & Plugs	T.B.A
BL-RM	A/C Coupling	71	UD-EL-7DP	Clean Out System	82
BL-TF45T	A/C Coupling	70	2000-60DC	Equipment & Tooling	T.B.A
BL-TF90T	A/C Coupling	70	2000-100DC	Equipment & Tooling	T.B.A

REUSABLE COUPLINGS

For SAE 100R1AT, 100R2AT & 100R5 HOSE

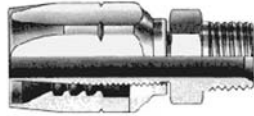

Reusable Male NPT

SAE 100R1AT

PART NUMBER	HOSE I.D.	THREAD
R104-02MP	1/4"	1/8"-27
R104-04MP	1/4"	1/4"-18
R106-04MP	3/8"	1/4"-18
R106-06MP	3/8"	3/8"-18
R108-06MP	1/2"	3/8"-18
R108-08MP	1/2"	1/2"-14
R108-12MP	1/2"	3/4"-14
R112-12MP	3/4"	3/4"-14
R116-16MP	1"	1"-11 1/2

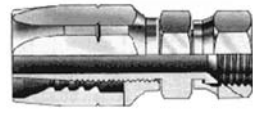

Reusable Female JIC Swivel

SAE 100R1AT

PART NUMBER	HOSE I.D.	THREAD
R104-04FJX	1/4"	7/16"-20
R104-06FJX	1/4"	9/16"-18
R106-06FJX	3/8"	9/16"-18
R106-08FJX	3/8"	3/4"-16
R108-08FJX	1/2"	3/4"-16
R108-10FJX	1/2"	7/8"-14
R112-10FJX	3/4"	7/8"-14
R112-12FJX	3/4"	1-1/16"-12
R116-16FJX	1"	1-5/16"-12

SAE 100R2AT

PART NUMBER	HOSE I.D.	THREAD
R204-02MP	1/4"	1/8"-27
R204-04MP	1/4"	1/4"-18
R206-04MP	3/8"	1/4"-18
R206-06MP	3/8"	3/8"-18
R208-06MP	1/2"	3/8"-18
R208-08MP	1/2"	1/2"-14
R208-12MP	1/2"	3/4"-14
R212-12MP	3/4"	3/4"-14
R216-16MP	1"	1"-11 1/2
R220-20MP	1-1/4"	1-1/4"-11 1/2
R224-24MP	1-1/2"	1-1/2"-11 1/2
R232-32MP	2"	2"-11 1/2

SAE 100R2AT

PART NUMBER	HOSE I.D.	THREAD
R204-04FJX	1/4"	7/16"-20
R206-06FJX	3/8"	9/16"-16
R206-06FSX*	3/8"	5/8"-18
R206-08FJX	3/8"	3/4"-16
R208-08FJX	1/2"	3/4"-16
R212-10FJX	3/4"	7/8"-14
R212-12FJX	3/4"	1-1/16"-12
R212-12FSX*	3/4"	1-1/16"-14
R216-16FJX	1"	1-5/16"-12
R220-20FJX	1-1/4"	1-5/8"-12
R224-24FJX	1-1/2"	1-7/8"-12
R232-32FJX	2"	2-1/2"-12

SAE 100R5

PART NUMBER	HOSE I.D.	THREAD
R504-02MP	3/16"	1/8"-27
R504-04MP	3/16"	1/4"-18
R505-04MP	1/4"	1/4"-18
R506-04MP	5/16"	1/4"-18
R506-06MP	5/16"	3/8"-18
R508-06MP	13/32"	3/8"-18
R508-08MP	13/32"	1/2"-14
R510-08MP	1/2"	1/2"-14
R510-12MP	1/2"	3/4"-14
R512-12MP	5/8"	3/4"-14
R516-16MP	7/8"	1"-11 1/2
R520-20MP	1-1/8"	1-1/4"-11 1/2
R524-24MP	1-3/8"	1-1/2"-11 1/2
R532-32MP	1-13/16"	2"-11 1/2

SAE 100R5

PART NUMBER	HOSE I.D.	THREAD
R504-04FJX	3/16"	7/16"-20
R505-05FJX	1/4"	1/2"-20
R506-04FJX	5/16"	7/16"-20
R506-05FJX	5/16"	1/2"-20
R506-06FJX	5/16"	9/16"-16
R506-06FSX*	5/16"	5/8"-18
R506-08FJX	5/16"	3/4"-16
R508-08FJX	13/32"	3/4"-16
R508-06FSX*	13/32"	5/8"-18
R510-08FJX	1/2"	3/4"-16
R510-10FJX	1/2"	7/8"-14
R512-12FJX	5/8"	1-1/16"-12
R512-12FSX*	5/8"	1-1/16"-14
R516-16FJX	7/8"	1-5/16"-12
R520-20FJX	1-1/8"	1-5/8"-12
R524-24FJX	1-3/8"	1-7/8"-12
R532-32FJX	1-13/16"	2-1/2"-12